

SEKONIC

OPTICAL
MARK READER

SR-1800

Operating manual

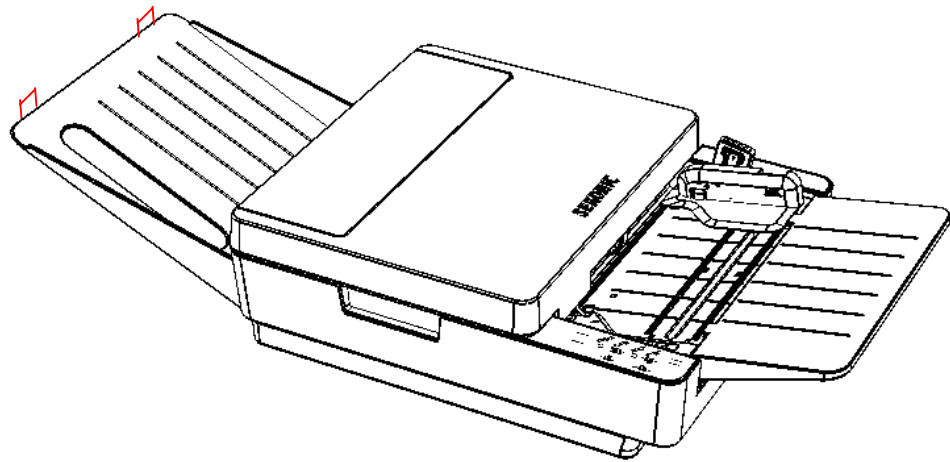

Introduction

Thank you very much for purchasing our product.

Please read the operating manual before using this product, and be sure to use it properly.

After reading this operating manual, be sure to keep it in a place that you can access at any time.

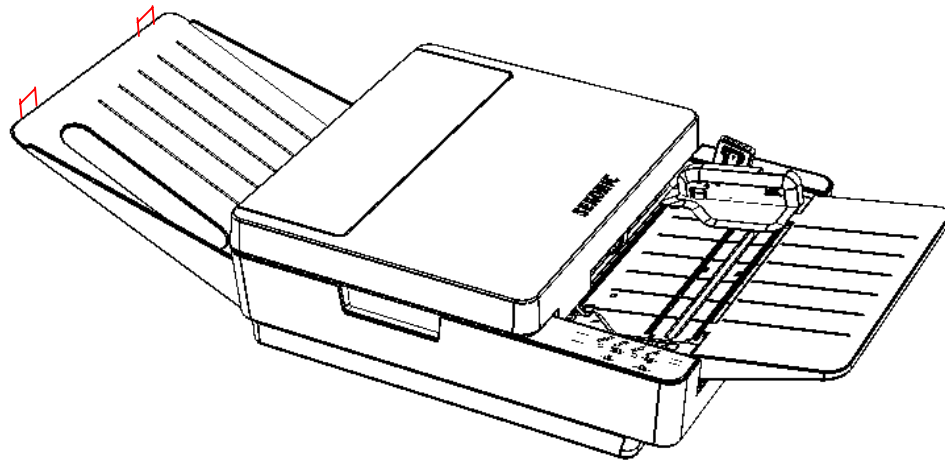

NOTICES

1. A part or all of contents of this manual may not be reproduced in any form without the prior written permission of the publisher.
2. The contents of this manual are subject to change without notice.
3. If you have any doubt or question about the product or the contents of this manual, please make contact with our sales division or service division.

Table of Contents

Safety Precautions	5
Warranty.....	8
Before Using	10
■ Before Using the Device	10
■ Unpacking the Device	11
Names and Functions of Parts	12
■ Main Body Unit	12
■ Operation Panel.....	12
■ Buzzer Sound.....	14
Preparation for Use.....	15
■ Attaching the Paper Feed Tray and Stacker.....	15
■ Connecting the AC Adapter.....	16
■ Connecting the Communication Cable	17
■ Connecting to the Computer	17
■ Rotary and DIP Switch Settings	18
1 Accessing the Rotary and DIP Switches	18
2 Rotary Switch RSW1 Settings.....	18
3 DIP Switch SW1 Settings	19
4 DIP Switch SW2 Settings	20
5 DIP Switch SW3 Settings	22
6 Rotary Switch RSW2 Settings.....	23
Inspecting Sheets	24
Handling and Storing Sheets.....	26
■ Handling sheets	26
■ Storage of sheets.....	26
Marking Instructions	27
About Reading Sensitivity Level	27
Operation.....	28
■ Operation Flow	28
■ Turning Power On/Off.....	28
1 Turning Power On.....	28
2 Turning Power Off.....	28
3 Power Saving Modes	29
■ Setting Sheets.....	30
■ Reading Sheets	32
■ Checksheet Reading Test	34
Troubleshooting.....	35
■ Troubleshooting	35

- Error Indicator.....36
- Fixing Paper Jams.....38
- Cleaning.....40
 - Regular Maintenance40
 - Cleaning Procedures.....41
- Service Schedule.....43
- Product Specifications.....44
- External Dimensions Diagram45
- OMR Glossary46
- Appendix.....52

Safety Precautions

These “Safety Precautions” pages list various symbols for ensuring safe operation of this product so as to prevent users or other people from being injured, or property from being damaged.





Read these precautions thoroughly and understand the meanings of the symbols before proceeding to the main text of this manual.

Warning

Improper operation by neglecting these instructions may result in death or serious injury.

Caution

Improper operation by neglecting these instructions may result in personal injury or property damage.

	Neglecting these instructions may generate smoke or fire.
	Neglecting these instructions may cause electric shock.
	Indicates a prohibited action.
	Indicates that disassembly or modification is prohibited.
	Indicates that the power plug must be removed from the outlet for safe operation.



Warning

- Fire or electric shock may result if this product continues to be used when there is a strange smell or sound. In such a case, immediately turn the power switch off and then remove the power plug from the outlet. After making sure that it is no longer smoking, ask the sales shop for repair service. Never attempt to repair by yourself since that may be very dangerous.



- Please do not modify or disassemble this machine. Doing so may result in fire or electric shock.
- Please do not remove the machine's cover (except for top cover). Doing so may result in electric shock. Please ask the sales shop for all internal inspections, adjustments, and repairs.
- Please do not modify or disassemble the included AC adapter. Doing so may result in fire or electric shock.



Strict care should be taken for the following points.

Otherwise, a fire or electric shock will be caused in some cases.

- Cautions to Power Cord
 - Do not pull on the cord when removing the power plug from the outlet.
 - Do not use any power cord other than the specified one.
- Cautions to AC adapter
 - Do not pull on the cord when removing the DC plug from the device.
 - Do not use any AC adapter other than the specified one.
Be sure to use the included AC adapter.
- Cautions to Device
 - Do not use the device with a supply voltage other than the specified one.
 - Do not install device in a place that may be wet with water or oil, steam, moisture or dust.
 - Do not insert or drop any metal, foreign combustible matter, etc. into the device from its opening.
 - Do not place containers with chemicals or water, or small metal pieces on or near the device.



Warning

- If the device is dropped or the cover is broken, immediately turn the power switch off and remove the power plug from the outlet. Then, contact the sales shop.



- If any foreign matter should enter inside, immediately turn the power switch off and remove the power plug from the outlet. Then, contact the sales shop or Sekonic. If the device continues to be used with foreign matter inside, fire or electric shock may occur.
If water or other substances penetrate the unit, immediately turn the power switch off and remove the power plug from the outlet. Then, contact the sales shop or Sekonic. If the device continues to be used with water or other foreign matter inside, fire or electric shock may occur.



- Before moving the device, be sure to remove the power plug from the outlet. If the cable is damaged, fire or electric shock may occur.



- Do not connect or disconnect the power plug if your hands are wet. Otherwise, an electric shock may occur.



Caution

- Do not place the device in an unstable location. Otherwise, it may fall or collapse, resulting in injury.



- When opening or closing the upper part of the main body, do not place your hand on the paper-feeding surface. Otherwise, fingers may be caught, resulting in injury.
- If you must touch the paper-feeding surface of the main body, be careful not to allow your fingers to be caught or hit.



- When doing maintenance on the device, for your own safety, be sure to remove the power plug from the outlet.
- When the device is not in use for long periods, for safety, remove the power plug from the outlet.



- Do not put heavy things on the device. Otherwise, it may fall or collapse, resulting in injury.



Warranty

The cost-free warranty period for this product extends for one year after delivery.

The company will repair malfunctions arising during this period free of charge if they are determined to be the company's responsibility. In the event repairs are necessary, as a general rule the company will keep the product temporarily to carry out such repair work.

Problems arising after the warranty period has expired, problems not covered by the warranty even if the warranty period has not expired, problems that do not have the seal of the retailer, malfunctions and other failures caused by customer misuse or by wear and tear of parts due to repeated use will not be covered by the warranty.

Please enter all necessary information on the Customer Card and FAX it to SEKONIC Corporation.

Following registration, we will return the warranty to you.

If there is no user registration, the free warranty will not be applied.

This warranty covers only this product and included accessories, and the company does not assume any responsibility for monetary damages, lost profits or any claims from third parties resulting from the use of this device.

Precautions for Use

Handle the device with the following points in mind to enable full use of its functions.

Precautions regarding installation

Do not place the device in the following places. Otherwise, failures could result such as paper jams, reading errors, or the unit could stop operating.

- (1) In direct sunlight or near a heating device.
- (2) Outdoors where the main body may not perform satisfactorily due to rain or strong wind.
- (3) Places where the machine may not perform satisfactorily, such as unstable or inclined surfaces, or other locations where the machine may shake while it is operating.
- (4) Places subject to sudden temperature changes, excessive moisture and dust.

Recommended temperature: 10-30°C (50-86°F)

Guaranteed operating temperature range: 5-35°C (41-95°F)

Humidity: 30-80% (no condensation)

Avoid environments outside the above ranges as much as possible.

Handling precautions

- (1) Do not connect or disconnect the power plug or DC plug of AC adapter when the device is operating or the power switch is on.
- (2) Do not move the device while it is operating. Also, do not touch, pull, or push paper.
- (3) Do not put objects on the device, or sit or lean on it.
- (4) Do not give the device a strong vibration and shock etc.
- (5) Allow an interval of at least 5 seconds between turning the power switch on and off.
- (6) Do not insert foreign objects other than paper.
- (7) Do not apply force that deforms paper while it is being loaded.
- (8) Since the paper reader is equipped with an optical lens, never insert a screwdriver or other such objects. (Otherwise, reading may be disabled.)
If paper feeding is disabled due to dust or the like in the paper feeder, open the top cover to remove it. (**Reference** “ Cleaning” P.40)
- (9) If the roller becomes soiled with powder from paper or pencil lead, the roller and the paper may slip. In order to prevent slippage, clean the roller at proper intervals. (**Reference** “ Cleaning” P.40)
- (10) If the exterior of the device is soiled, lightly wipe with a soft cloth wetted with water or a neutral detergent. Note that wiping with a cloth wetted with volatile chemicals like benzene or paint thinner may cause deformation or discoloring.
- (11)  Do not place excessive load on the paper feed tray and stacker. Doing so may result in deformation or damage.
- (12) When the machine is not used for a prolonged period of time, remove the power cord from the outlet.
- (13) When the machine is not used for a prolonged period of time, keep the hopper set in the down position.

Before Using

■ Before Using the Device

Before using the device, check if all of the following items are included in the package. If parts are missing or damaged, contact the store where you purchased the device.

1. Main body unit

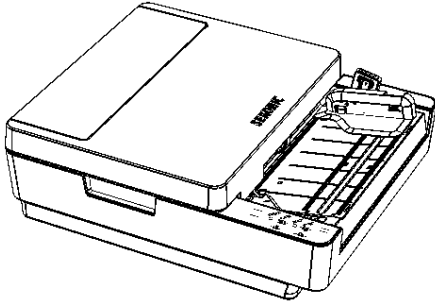

2. Stacker

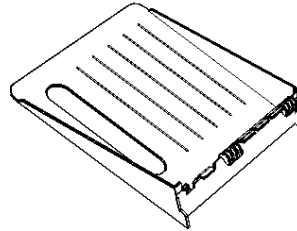

3. Paper feed tray

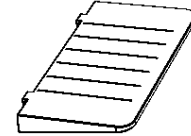

4. Power cord
For U.S.A

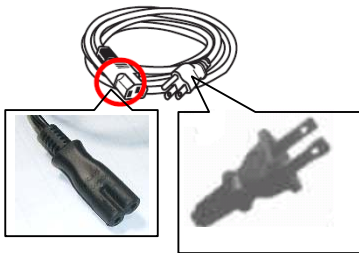

For Europe

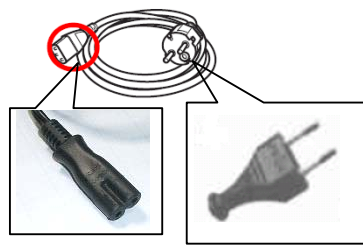

5. AC adapter



6. Quick guide

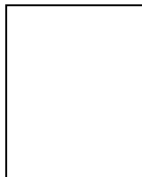

7. A4 checksheets (5 sheets)

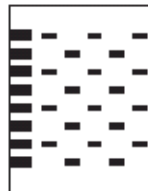

Checksheet:
Use it for checking
OMR operations.

8. CD-ROM

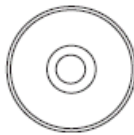

9. USB cable



Note

The package does not include a RS-232C interface cable. You will need to purchase one depending on your computer port or connection method.

* RS-232C Specifications on OMR side: 9 pin straight cable

■ Unpacking the Device

The following parts are fixed with tape to prevent damage in shipping.

- (1) The device is fixed with tapes ① (3 places)
- (2) Hold Part A of the top cover and open it, pull upward and remove it.
- (3) Remove the cushioning material ② from the top cover. (1 place)
- (4) Reattach the top cover.

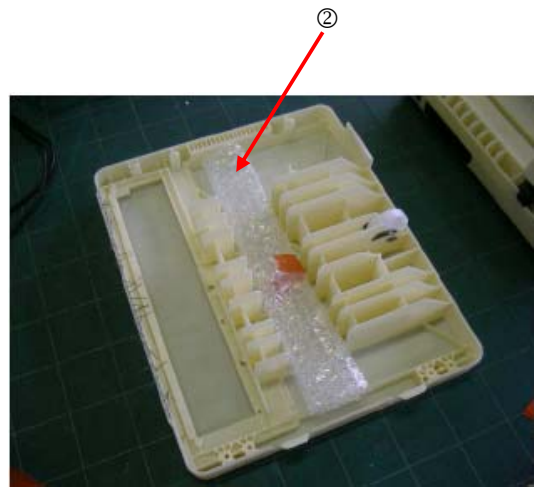
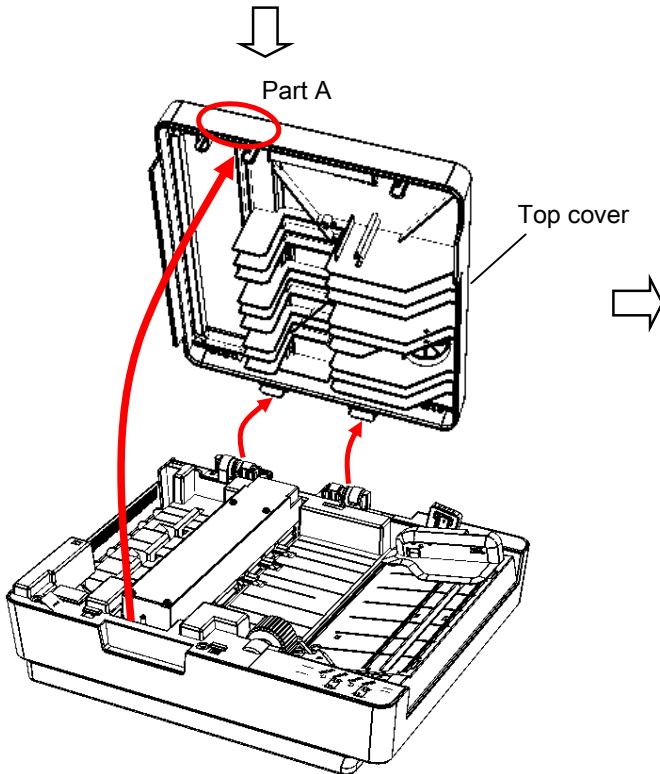
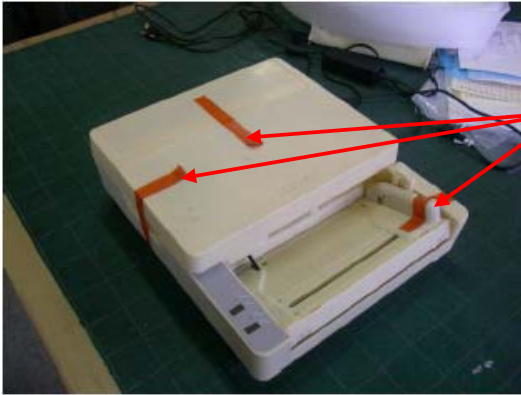

[Top Cover]

Names and Functions of Parts

■ Main Body Unit

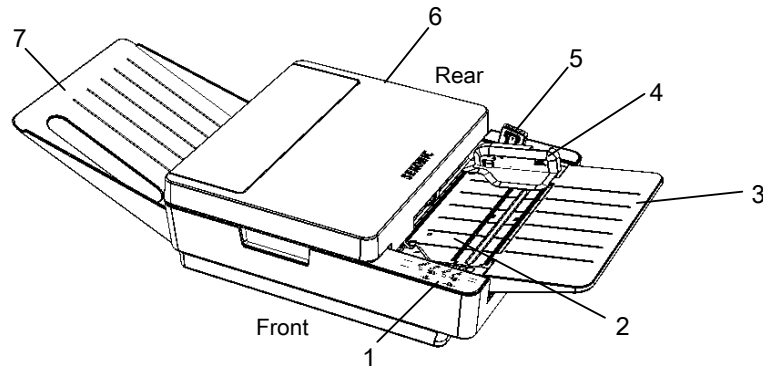

Number	Name	Explanation
1	Operation panel	Refer to " ■ Operation Panel" . (P.12)
2	Hopper	Part for loading paper.
3	Paper feed tray	Tray for paper supply. (removable)
4	Paper guide	Adjusts width to match paper width.
5	Lock lever	Lock lever for the hopper. When setting paper, push this lever to lower the hopper. After setting paper, push the lock lever release claw of the lock lever to unlock. The hopper will return to the paper supply position.
6	Top cover	Remove when cleaning the reader or rollers, and when removing paper after a paper jam has occurred.
7	Stacker	Tray for discharged paper. (removable)

■ Operation Panel

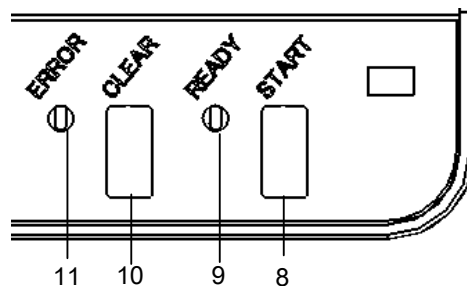

Number	Name	Explanation
8	START switch	When pressed once, one sheet of paper is sent through. When pressed continuously, paper is sent through repeatedly.
9	READY lamp	Lights up when the power is on. Indicates that the device is able to communicate with the computer.
10	CLEAR switch	Clears errors. When pressed, the ERROR lamp turns off.
11	ERROR lamp	Lights up during the self-check after the power is turned on, and turns off when the check is complete. Lights up or blinks when an error occurs.

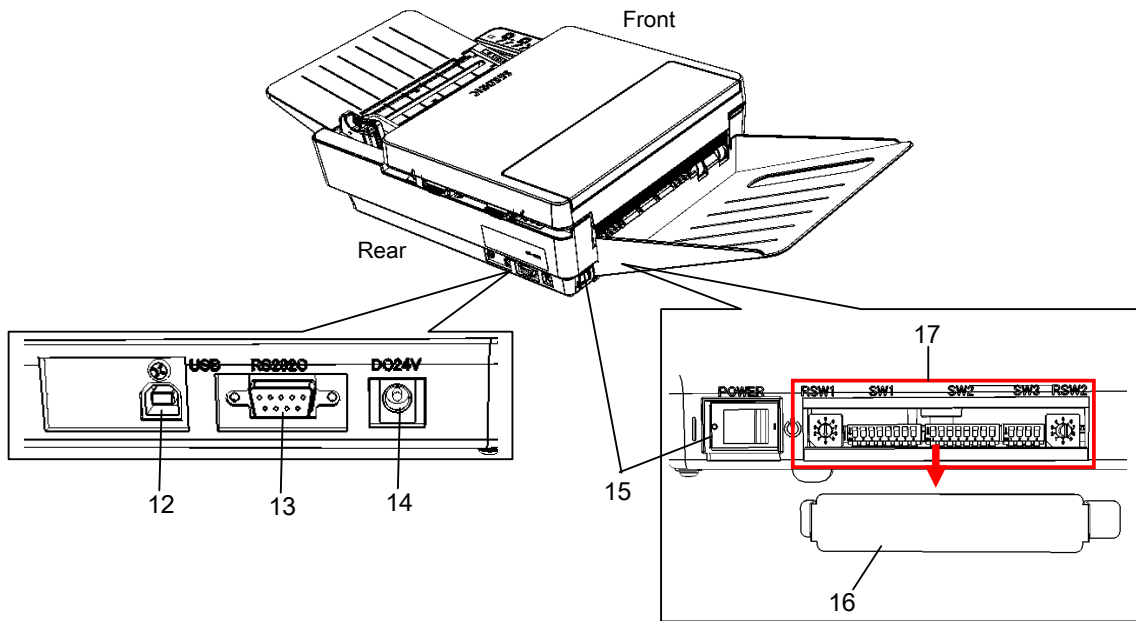

Number	Name	Explanation
12	USB connector	Port for communication via USB cable.
13	RS-232C connector	Port for communication via RS-232C.
14	DC jack	DC plug (AC adapter) connection terminal.
15	Power switch	Turns the device ON/OFF.
16	DIP Switch cover	Cover for the DIP switch. Bend the cover to remove it.
17	DIP/Rotary switches	Switches for setting device specifications. Before using the device, the switches must be set. (Reference: “ ■ Rotary and DIP Switch Settings” (P.18))

■ Buzzer Sound

This device has a built-in buzzer that indicates operating conditions and errors.

Buzzer Sound	Meaning	Explanation
Pip!	Confirmation	When the power is on, the buzzer sounds after the self-check is completed normally. (Sounds at the same time the ERROR lamp turns off.)
		Sounds when the START switch is pressed and paper is loaded.
		Sounds when the CLEAR switch is pressed and the ERROR lamp turns off.
Pip! Pip! Pip!	Caution	Sounds when no paper is in the hopper and the START switch is pressed.
		Sounds when an abnormality occurs during the checksheet reading test.
Peep! Peep! Peep!	Error	Sounds when an error occurs.

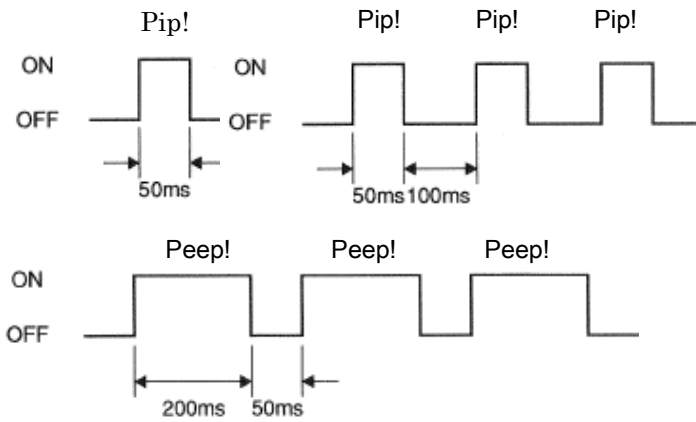

Preparation for Use

Prepare the device for use by following the procedure below.

Reference: For information on unpacking the device, refer to “ ■ Unpacking the Device” (P.11).

■ Attaching the Paper Feed Tray and Stacker

Attach the paper feed tray and stacker to the main body unit as shown in the diagram below.

- (1) Attach the paper feed tray to the side of the main body unit where paper is fed.
Insert the hooks (2) of the paper feed tray into the corresponding holes on the main body unit.

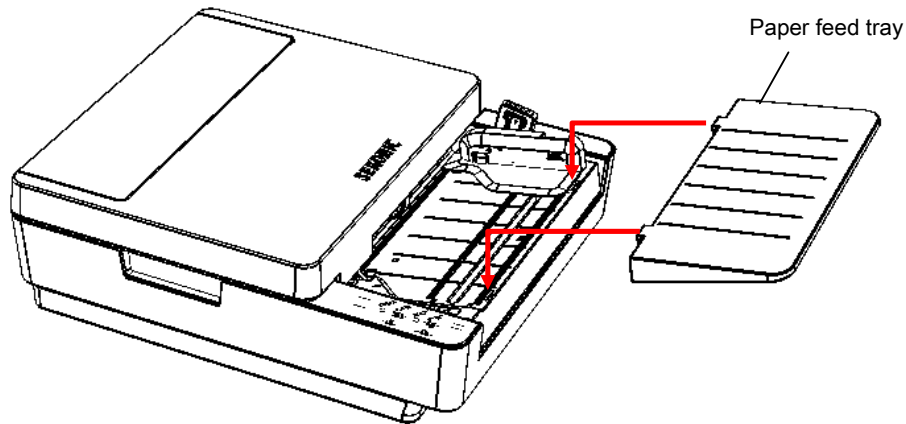

- (2) Attach the stacker to the side of the main body unit where paper is discharged.
Hook the hooks (2) of the stacker into the corresponding holes on the main body unit.

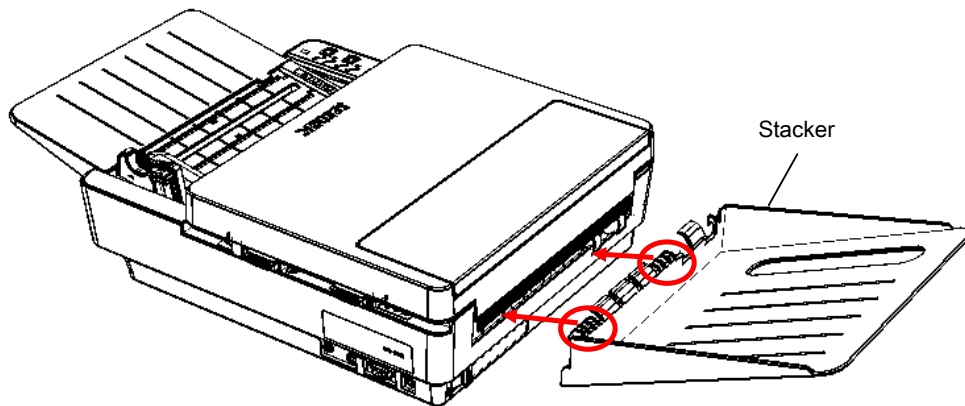

■ Connecting the AC Adapter

Attach the AC adapter (included) to the device.



WARNING

- Be sure to use the included AC adapter, otherwise a fire may result.

- (1) Insert the DC plug of the AC adapter into the main body unit's DC jack.
- (2) Connect the power cord to the AC adapter and the outlet.

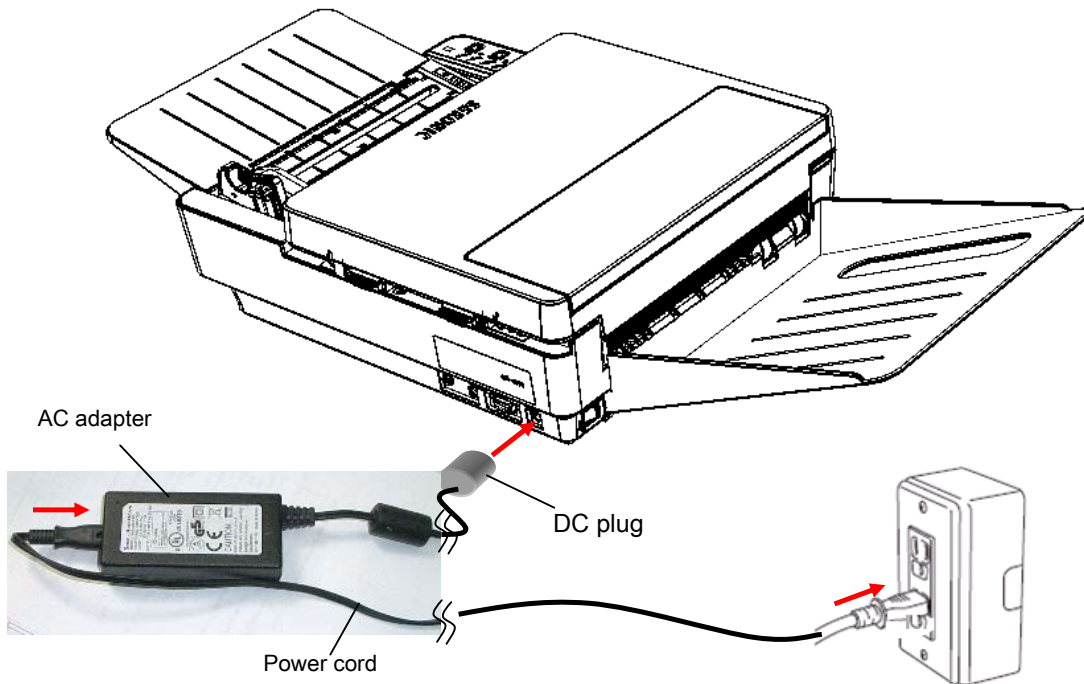

■ Connecting the Communication Cable

Connect the USB cable (included) or RS-232C interface cable.

(1) Connect the USB cable to the USB connector.

If the RS-232C port is used, connect the RS-232C interface cable to the RS-232C connector.

- CAUTION**
- Only either port (USB or RS-232C) can be used.
 - An RS-232C interface cable is not included with the product. Find one to match your computer and connection method.
 - If the RS-232C port is used, the rotary switch and DIP switch must be set properly. (**Reference:** “ ■ Rotary and DIP Switch Settings” (P.18))

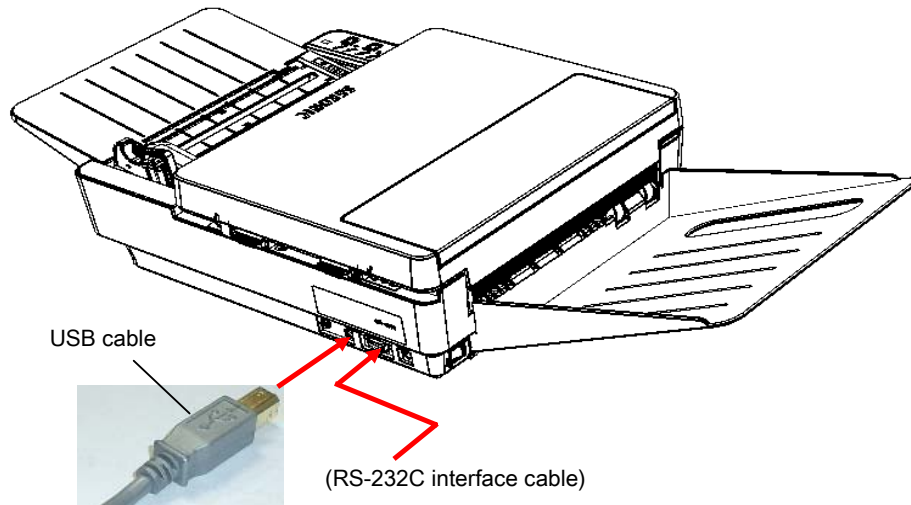

■ Connecting to the Computer

This device is equipped with USB and RS-232C interfaces. If an OMR is newly installed, it is recommended that you connect to USB interface in order for the device to obtain the best performance. In such a case, use the USB driver on the included CD-ROM.

When this device is replaced with an OMR SR-600 series device, this device can simply be used by using the RS-232C interface. *1

If RS-232C is used, make sure the communications settings for the device and the computer are the same. Set the computer's communications settings after referring to the computer or software user's manual.

*1: Depending on the environment/system used, it may not function properly.

Configure the device's communications settings via the following:

- Switch the USB and RS-232C interfaces
 - Adjust settings using the DIP switch (SW3-1 and -2). (**Reference:** “ 5 DIP Switch SW3 Settings” (P.20))

* For details on the SR-1800 mode commands, refer to the “ OMR Command Reference Manual” and “ API Reference Manual for Windows” on the included CD-ROM.

* For details on the SR-600 mode commands, refer to the SR-600 Series Operation Manual.

■ Rotary and DIP Switch Settings

The device is shipped from the factory with default settings. Configure the number of lines to read and device function settings according to its intended use.

If the RS-232C port is used, configure the communication speed and data format settings.

1 Accessing the Rotary and DIP Switches

- (1) Remove the stacker from the main body unit.
- (2) Bend and remove the DIP switch cover on the bottom left of the stacker side.
(Reattach it after set up is complete.)

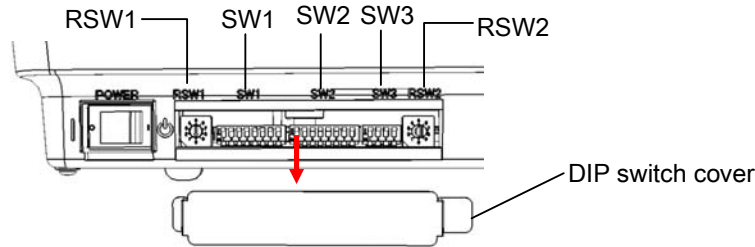

2 Rotary Switch RSW1 Settings

Set the communication speed of the RS-232C port.

CAUTION • Be careful when configuring settings. Communication errors will occur if settings are incorrect.

- Make sure the power is off when configuring settings.

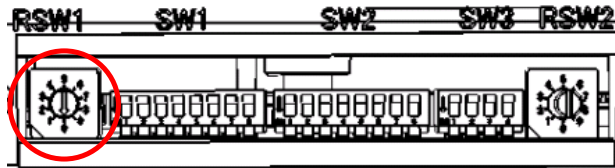

■ : Indicates the factory settings.

SW No.	Baud rate [bps]
0	9,600
1	19,200
2	38,400
3	57,600
4	115,200
5 to 9	(Not used)

3 DIP Switch SW1 Settings

Configure RS-232C port communication format and other settings.

CAUTION • Be careful when configuring settings. Communication errors will occur if settings are incorrect.

- Make sure the power is off when configuring settings.
- DIP switch 1-6 (SW1-6) is the back-side reader setting, unrelated to the RS-232C settings. It is set to ON for double-sided specification. Meanwhile, it is set to OFF for single-sided specification.

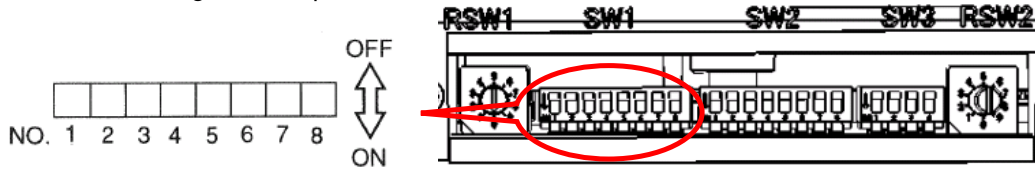

■ : Indicates the factory settings.

No.	Contents of setting	ON/OFF	Explanation
1	Character bit length	ON	8
		OFF	7
2	Parity	ON	Absent (Non)
		OFF	Present (Valid)
3	Parity	ON	Odd
		OFF	Even
4	Stop bit length	ON	1
		OFF	2
5	Code acceptance status	ON	All codes are accepted.
		OFF	(See Note. 1)
6	Back side reading	ON	For double-sided specification
		OFF	For single-sided specification
7	Protocol control	ON	Enabled
		OFF	Disabled
8	Protocol	ON	RS/CS
		OFF	Xon-Xoff

Note 1: According to the setting of “ Code Acceptance Status,” it is possible to ignore the ASCII codes below when processing commands and data received by the device. Depending on the computers that are connected and programs used, it may be necessary to configure this setting.

Codes ignored: 20H, 0AH, 7FH, 1AH

4 DIP Switch SW2 Settings

CAUTION • Be careful when configuring settings. Marks will be misread if the settings are incorrect.

- Make sure the power is off when configuring settings.



 : Indicates the factory settings.

Contents of setting		SW2							
No. of lines	Timing type	1	2	3	4	5	6	7	8
12 lines	Control type	ON	ON	ON	OFF				
	Direct-under type	OFF	OFF	OFF	ON				
	Mark-to-mark type	OFF	OFF	ON	ON				
24 lines	Control type	OFF	OFF	ON	OFF				
	Direct-under type	ON	OFF	ON	OFF				
	Mark-to-mark type	ON	ON	OFF	OFF				
32 lines	Control type	OFF	ON	OFF	OFF				
	Direct-under type	ON	ON	OFF	ON				
	Mark-to-mark type	OFF	ON	OFF	ON				
38 lines	Control type	OFF	ON	ON	ON				
	Direct-under type	ON	ON	ON	ON				
40 lines	Control type	OFF	OFF	OFF	OFF				
	Direct-under type	ON	OFF	OFF	OFF				
	Mark-to-mark type	ON	OFF	OFF	ON				
48 lines	Direct-under type	ON	OFF	ON	ON				
Automatic paper discharge		ON				ON			
		OFF				OFF			
Paper empty detection		ON					ON		
		OFF					OFF		
Timing mark error detection		ON						ON	
		OFF						OFF	
(Not used)		-							ON
		-							

SW2-1 to 4: Select the number of lines to read and the timing mark type according to the paper used. Mark-to-mark type is set for “ Without top-end margin reading.”

(Reference: ” OMR Glossary” (P.46) - “ Timing control type,” “ Direct under type,” “ Mark to mark type”)

Priority is given to the settings from the computer side.

SW2-5: Select automatic paper discharge. When it is ON (factory setting) and an error related to automatic paper discharge (see below) occurs, the sheet of paper will be discharged automatically.

(This function becomes effective when the setting for SW3-3 “ Paper Hold” is ON. The factory setting is OFF.)

List of Errors for Automatic Discharge:

No.	Error	Automatic discharge
1	Sheet empty	×
2	Timing mark error	○
3	Double feed error	○
4	Edge skew error	○
5	Mark skew error	○
6	Paper jam or paper remaining	×
7	Other error	○

○:Automatic discharge on ×:Automatic discharge off

SW2-6: Select sheet empty detection. When it is ON and a “ paper read command” is received, it will detect the absence of paper if there is no paper in the hopper. The factory default setting is OFF (absence of paper will not be detected).

SW2-7: If there are three or less timing marks on the sheet that was read, a timing mark error will be detected (detection is made as the factory setting is ON.)

5 DIP Switch SW3 Settings

- CAUTION** • Be careful when configuring settings. Malfunction will occur if the settings are incorrect.
- Make sure the power is off when configuring settings.

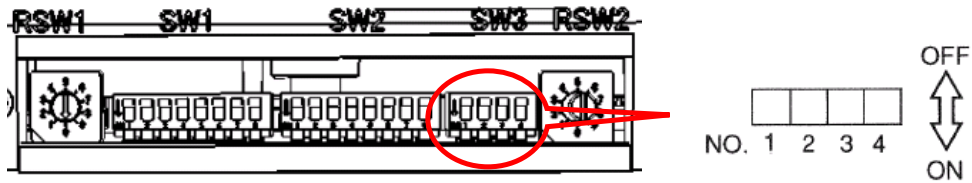

 : Indicates the factory settings.

Contents of setting	SW3			
	1	2	3	4
Operation mode				
SR1800 Mode (USB connection mode)	OFF	OFF		
(Not used)	ON	OFF		
SR600 Mode (RS-232C connection mode)	ON	ON		
Paper hold	ON		ON	
	OFF		OFF	
Edge skew detection	ON			ON
	OFF			OFF

SW3-1 to 2: Preset to “ SR1800 Mode (USB connection mode).” If an existing SR-600 model is replaced with this device and the RS-232C interface is used, set this switch to “ SR600MODE (RS-232C connection mode).”

SW3-3: Select whether or not to hold the read paper. When it is ON, the read sheet will be stopped at the paper discharge part. The factory setting is OFF so that the read paper will be discharged to the stacker.

SW3-4: Select whether or not to enable edge skew detection. The factory setting is ON (enabled) so that if the sheet is skewed above a certain value, there will be an error, and the paper reading will stop.
If it is set to OFF (disabled), there will be no error even if the sheet is skewed, and the paper will be read.

Edge skew detection:

The edge skew detection is the function to detect whether a sheet was fed straight.

Therefore, a skew error may be detected for the following sheets when the SW3-4 is turned ON.

- Sheet with perforations
- Sheet with large cut deviations
- Curled or folded sheet

Example:

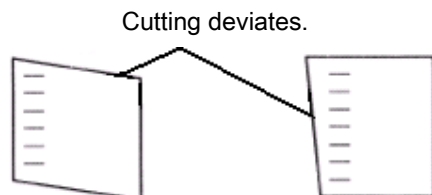

6 Rotary Switch RSW2 Settings

- CAUTION**
- Be careful when configuring settings. Malfunction will occur if settings are incorrect.
 - Make sure the power is off when configuring settings.

Set the paper weight to match the paper to be used. This setting is used for double feed detection.

Reference: "Reading Sheets" (P.32)

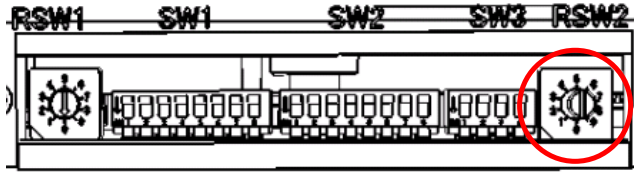

■ : Indicates the factory settings.

SW No.	Paper weight
0	Double feed detection disabled
1	72kg (84g/m ²)
2	90kg (105g/m ²)
3	110kg (128g/m ²)
4	135kg (157g/m ²)
5	160kg equivalent (186g/m ²)
6 to 9	(Not used)

When double feeding occurs:

The device's automatic paper feed unit has a detection function to inform of an error when double feeding has occurred.

The double feeding detection function uses a transmission-type sensor to determine whether double feeding has occurred by the difference in the amount of transmitted light due to the thickness of the paper.

Set the double feed detection according to the thickness of paper being used.

Settings are configured using the rotary switch RSW2, with a factory setting of 90kg (RSW2=2).

The table below indicates the relationship between the rotary switch setting and the paper weight/paper thickness.

CAUTION Depending on the paper quality, the device may detect a double feed error when only one sheet of paper passes through. In such a case, try increasing the setting value by one level.

e.g.: If double feed error occurs with RSW2 set at " 2" (90kg), select " 3" (110kg).

■ : Indicates the factory settings.

SW No.	Paper weight	Paper thickness (approx.)
0	Double feeding detection disabled	-
1	72kg (84g/m ²) OCR paper	(0.11mm)
2	90kg (105g/m ²) OCR paper	(0.13mm)
3	110kg (128g/m ²) OCR paper	(0.15mm)
4	135kg (157g/m ²) OCR paper	(0.18mm)
5	160kg equivalent (186g/m ²) OCR paper	(0.21mm)
6 to 9	Not used	-

Inspecting Sheets

Inspect sheets according to the following procedure to make sure there are no problems.

(1) Checking for dirty or damaged sheets

Check that the sheets are free from any dirt, rumples, folds, folding lines, turn-over, tears or bending. Do not make the device read sheets in which tears were mended with adhesive cellophane tape, etc.

If the above operation is forced, it will lead to a feeding error, sheet jam, misfeed or double feed.

Example:

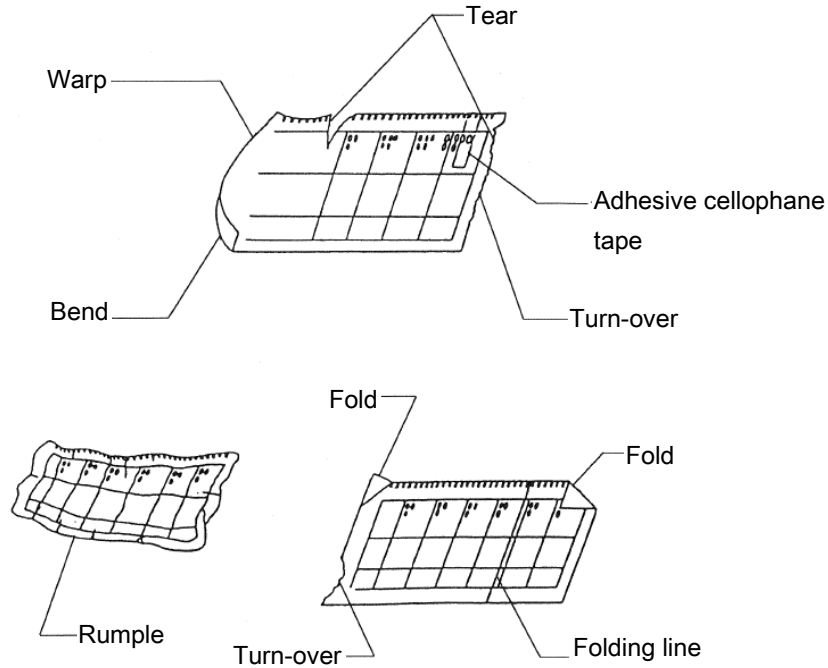

(2) Removing foreign materials

Check that the sheets are free from any foreign materials such as rubber eraser refuse, paperclips, adhesive cellophane tape, staples, rubber bands and correction liquid.

If the device is forced to read sheets with such foreign materials, it will lead to a feeding error or sheet jam. Also, it may result in damage to the feeder lens.

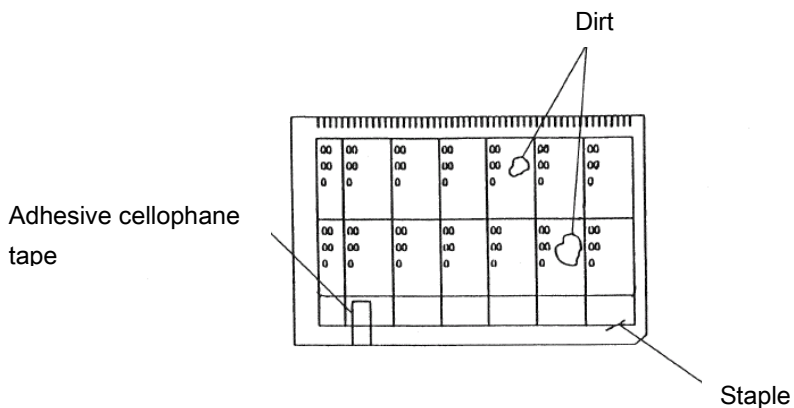

(3) Correcting curled or deformed sheets

Fix curled sheets or deformed sheets if they are found.

If the device is forced to read curled or deformed sheets, it will tend to cause a reading error, sheet jam, misfeed or skewed feed.

Straight, good sheets

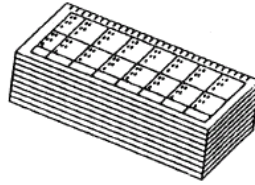

Upward curled sheets

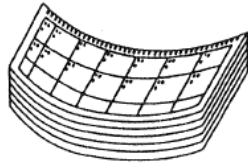

Downward curled sheets

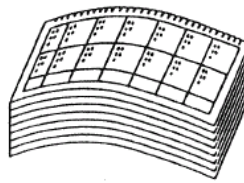

(4) Correcting folded sheets

Flatten 2- or 4-folded sheets before using them since it may cause a reading error. Make a sheet check when using them.

Do not use folded sheets of A6 size or less which weigh 110-kg or more.

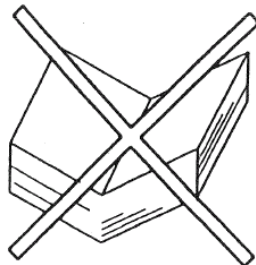

Handling and Storing Sheets

Sheets are affected by their handling and ambient conditions (especially temperature and humidity) and their characteristics may change, resulting in a reading error.

CAUTION:

Handle and store sheets with extreme care.

■ Handling sheets

- (1) Do not fold or blemish sheets, as a reading error may occur.
- (2) Keep sheets free from foreign materials such as oil and dust.
- (3) Do not use dirty sheets or those with torn edges since they will affect reading or cause a sheet jam.
- (4) If the temperature or humidity suddenly changes, keep sheets in the new conditions for about an hour, allowing them to adjust to the new conditions.
- (5) Do not expose sheets to direct sunlight for a long period of time.

■ Storage of sheets

- (1) Avoid storing sheets in a place where ambient conditions can suddenly change.
- (2) Store sheets in a cabinet, etc. to protect them from humidity.
- (3) Avoid storing sheets near windows or other locations where they may become dusty.
- (4) Store sheets on a flat surface so that they do not bend.

Marking Instructions

Marks readable by this device are as follows.

- (1) Mark size: 0.5 x 3mm or more (recommended mark)
- (2) Readable writing instruments: pencils (black, HB or darker), ballpoint pens (black or blue)
- (3) Readable marks: Filled-in spaces, ●, ×, ✓



CAUTION ●, ×, ✓ must have a filled-in area of at least 0.5mm X 3mm (recommended mark size)

- (4) Readable mark darkness: PCS 0.6 or darker

Readable mark darkness can be adjusted.

You can check mark darkness using a diagnostic utility included in the package, so check the darkness of the marks you want to read and adjust the reading setting on the computer side.

REFERENCE " About Reading Sensitivity Level" (P.27)

CAUTION When using a pencil or mechanical pencil, make sure to mark with adequate darkness.

About Reading Sensitivity Level

When this device is operating in the SR-600 mode, it is possible to set the reading sensitivity level with a command from a computer.

The reading sensitivity level ranges from 1 through 16, with Level 1 having the maximum reading sensitivity and Level 16 having the minimum reading sensitivity.

The table below compares the reading sensitivity levels of this SR-1800 device with the conventional SR-600 device.

Comparison Table of SR-1800 and SR-600 Reading Sensitivity Level Approximate Values:

SR-1800 Sensitivity Level	SR-600 Sensitivity Level	SR-1800 Sensitivity Level	SR-600 Sensitivity Level	SR-1800 Sensitivity Level	SR-600 Sensitivity Level
1	1	7	5 to 6	12	10 to 11
2	1 to 2	8	6 to 7	13	10 to 11
3	2 to 3	9	7 to 8	14	11 to 12
4	3 to 4	10	8 to 9	15	12 to 13
5	4 to 5	11	9 to 10	16	13 to 14
6	5 to 6				

*1: The above sensitivity levels are the approximate values for marks filled in using SEKONIC Corporation measurement methods.

*2: Both devices have different reading methods, so there are differences in levels depending on the mark.

*3: If SW3-1 and -2 are set to " SR600MODE" and used in the compatible mode, sensitivity levels must be checked by the user.

Operation

■ Operation Flow

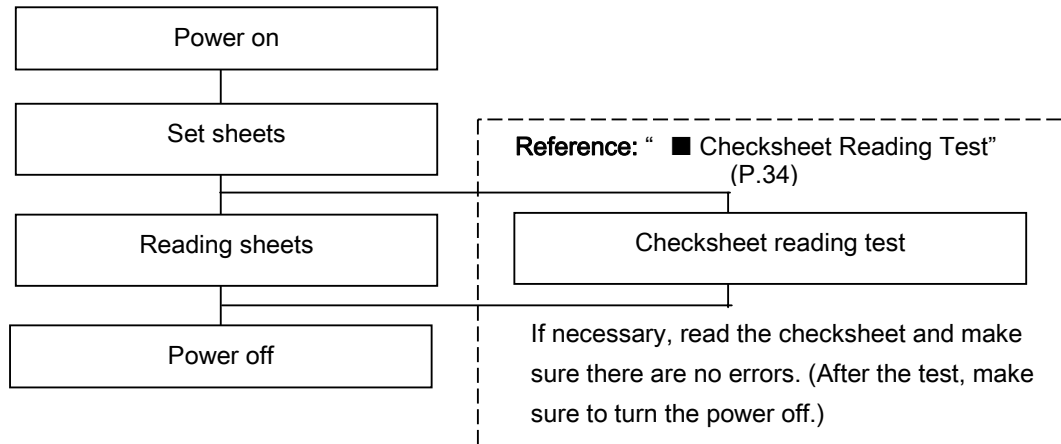

■ Turning Power On/Off

1 Turning Power On

- (1) Turn the power switch to ON position.

Power is turned on and the self-check begins. Then the READY lamp (green) and ERROR lamp (red) light up.

When the self-check is completed normally, the buzzer sounds “ Pip!” and the ERROR lamp turns off. Only the READY lamp turns on, indicating that the device is able to communicate with the computer.

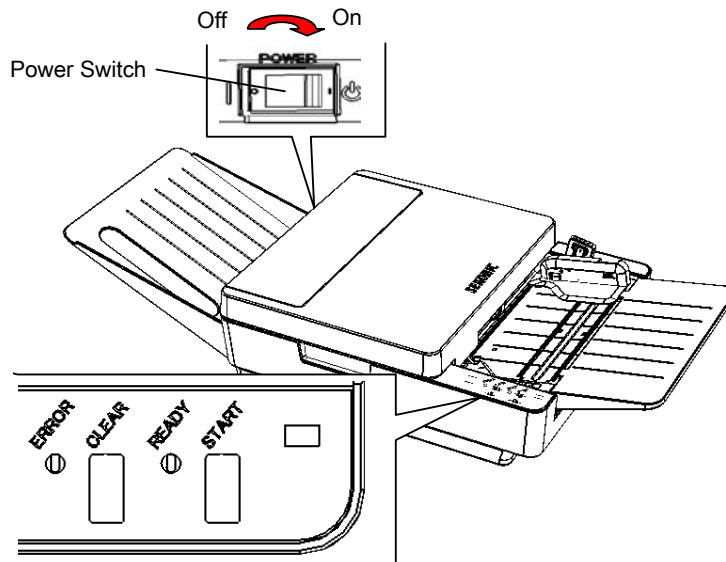

2 Turning Power Off

- (1) Turn the power switch to OFF position.

3 Power Saving Modes

After turning the power on, if the device is not operated for a certain period of time, the device will automatically enter power saving mode and power consumption will be minimized. The following are two types of power saving modes:

Power saving sleep mode	If device is not operated for 5 minutes, it will enter power saving sleep mode, and the READY lamp will blink repeatedly at fast intervals. Power consumption will be reduced.
Power saving standby mode	After entering the power saving sleep mode, if the device is not operated for another 5 minutes, it will enter power saving standby mode. The READY lamp will blink repeatedly at slow intervals and power consumption will be minimized.

Power Saving Sleep Mode (Fast blinking)

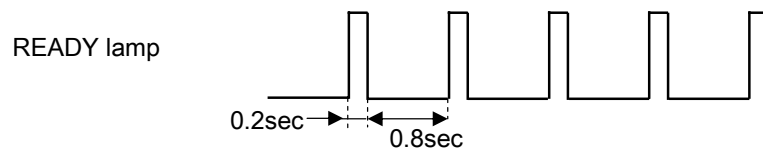

Power Saving Standby Mode (Slow blinking)

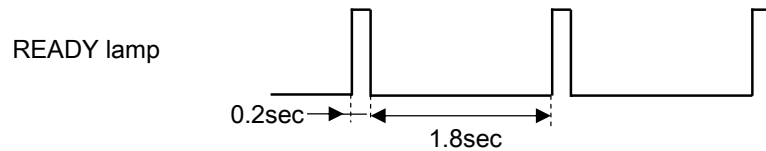

Deactivating Sleep/Standby Modes:

The sleep/standby modes will be deactivated when the following occur:

- Operation is performed using the operating panel.
- Operating command is received from the computer.
- An error has occurred.
- Sheets are set in the hopper.

Cases When Device Cannot Enter Sleep/Standby Mode:

- There is an error.

■ Setting Sheets

- (1) Push the lock lever down.

When the hopper is lowered to the position where the sheets are set, there will be a clicking sound and it will lock.

- (2) Set sheets straight so that their timing marks are on the left side viewing from the paper feed direction.

CAUTION If the front edge and side edge of the sheets are not aligned, it will result in a paper feeding error or skewed sheets.

- (3) Slide the paper guide so that there is no space between it and the sheets.

CAUTION • When there is space between the sheets and the paper guide, it may result in a reading error.

- Refer to the “ Sheet Setting Example” on the next page, and check that the sheets are set properly.

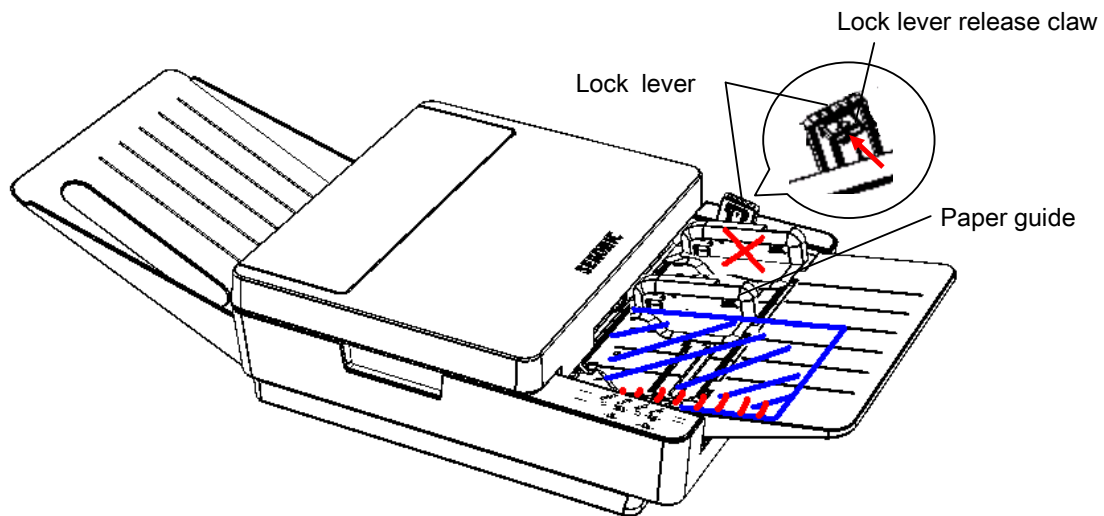

- (4) Push the lock lever release claw on the inside of the lock lever in the direction of the arrow (toward the operation panel side) to unlock the hopper.

The hopper will move upward and return to the paper feeding position.

Sheet Setting Example:

[Good example]

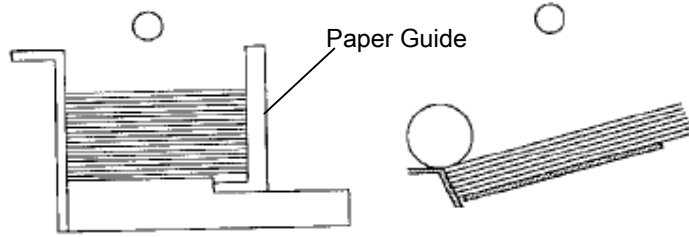

[Bad examples]

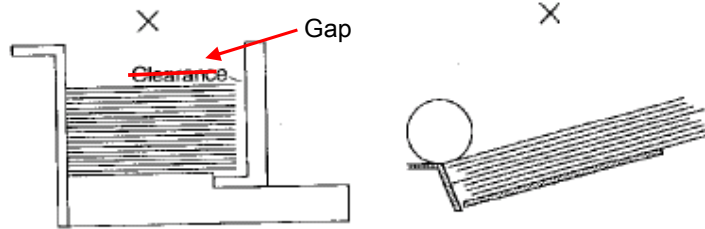

A gap exists either on the right or left side although the sheets are aligned.

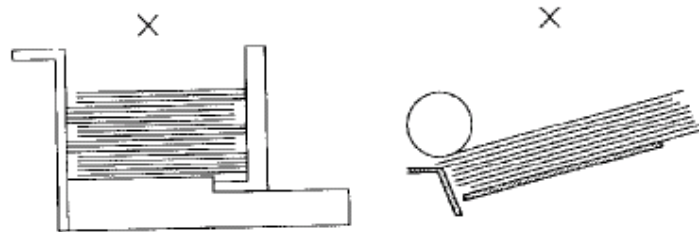

The sheets are not aligned although no gap exists.

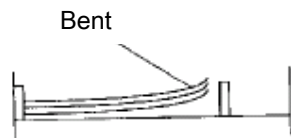

[Bad example]

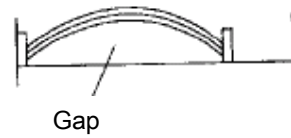

[Bad example]

■ Reading Sheets

This section explains the procedure for reading sheets.

(If you perform the checksheet reading test, please refer to “ Checksheet Reading Test” (P.34))

- (1) Turn the power switch on.

The power turns on and the self-check begins. The READY lamp (green) and the ERROR lamp (red) both light up. When the self-check is completed normally, the buzzer sounds “ Pip!” and the ERROR lamp turns off.

- (2) Set the sheets in the hopper.

Align the sheets so that the timing mark is on the left side viewing from the feed direction.

CAUTION • Refer to “ ■ Setting Sheets” (P.30) and set the sheets correctly.

- Be careful not to bend, fold, or damage the sheets. Doing so may result in a paper feeding error or reading error.
- Make sure to loosen the sheets before using them. Double feeding may occur if they are stuck to each other due to static electricity, burr, etc.



Adding sheets:

When adding sheets, lower the hopper and make sure to reset the sheets. Not doing so may result in a feeding error.

Maximum Hopper Capacity:

50 sheets, regardless of the weight of the paper

CAUTION Overloading sheets onto the hopper may result in paper feeding and reading errors.

Paper Size:

This device can use paper between 110mm and 335.6mm (4.3 inches to 14 inches) long, and between 63.5mm and 228.6mm (2.5 inches to 9 inches) wide.

The length of the sheet must be at least 1.3 times the width.

The paper quality must be “ OCR Paper” and the paper weight must be 72 to 135kg (83.8 to 157 g/m²).

CAUTION Do not use paper other than those with the specified size, quality, and weight.

- (3) Press the START switch, or send a command from the computer to read the sheet.

One sheet will be fed to device.

If the START switch is held down, the sheets will be fed continuously to the device.

If you want to obtain mark data of the sheet that was fed, send the “ Get Mark Density” command. (**Reference:** For details on commands, please refer to the “ Command Reference Manual.”)

- (4) When finished, turn the power off.

When an error occurs:

The buzzer sounds and the ERROR lamp (red) turns on or blinks. (**Reference:**
“ Troubleshooting” (P.35))

When the CLEAR switch is pressed, the ERROR lamp turns off.

■ Checksheet Reading Test

The included checksheets (with printed data marks) can be used to test the device's reading function.

CAUTION Perform this test before starting work and when checking the reading function.

- Turn the power on while pressing the CLEAR and START switches on the operating panel. Check that the READY lamp is blinking fast.

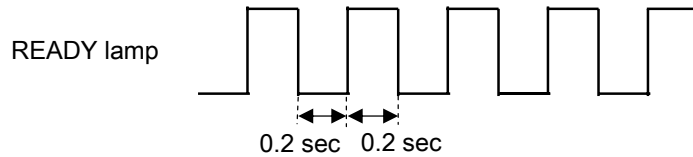

- Set the checksheet in the hopper. Set the checksheet so that the timing marks are on the left side in the feeding direction. Set the checksheet so that the corner cut is in the upper right as shown below.

CAUTION

- Refer to “ ■ Setting Sheets” (P30) and set the sheets correctly.
- Be careful not to bend, fold, or damage checksheet. Doing so may result in a paper feeding error or reading error.

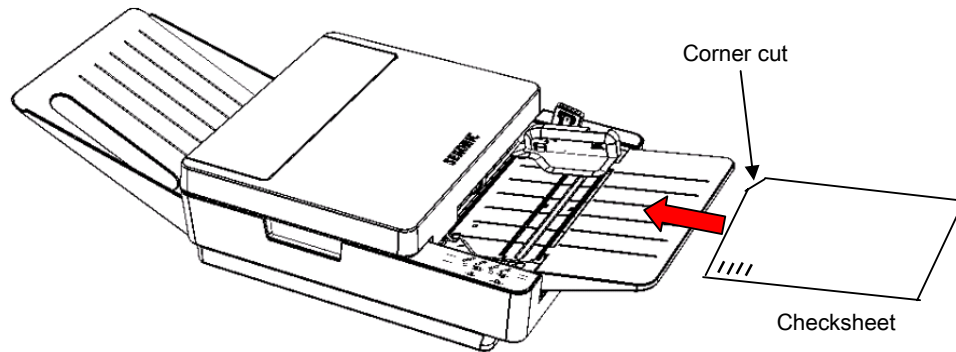

- Press the START switch.

CAUTION Once the START switch is pressed, reading operation will not stop even if there is a reading error or skew error, and checksheets will be fed continuously until there are no checksheets left.

- Confirm that there are no errors.

Error Status	ERROR Lamp (Red)	Buzzer Sound	READY Lamp (Green)
No reading error	-	-	Blinking
Reading error	-	“ Pip! Pip! Pip!”	Blinking
Skew error	Blinking	“ Peep! Peep! Peep!”	Blinking

Skew Detection:

Skew detection is for checking whether or not the sheet has been fed straight. The detection becomes effective when the DIP Switch SW3-4 is set to ON (factory setting is ON).

(Reference: “ 5 DIP Switch SW3 Settings” (P.22))

- Turn the power off to exit the checksheet reading mode.

CAUTION Make sure to turn the power off briefly right before regular sheet reading.

Troubleshooting

Before assuming that the device is broken, check the following. If you are still unable to solve the problem, please contact the store where you purchased the device.

■ Troubleshooting

Error Status	Cause	Action
Power does not turn on.	AC adapter and power cord are not properly connected.	Connect them properly. Reference: " Connect the AC Adapter" (P.16)
ERROR lamp (red) turns on.	Refer to " Error Messages" on the following page.	
Unable to read.	The reading sensor pitch and the mark pitch of the sheet do not match.	Use a matching sheet.
	The timing mark shape and the read timing setting do not match.	Match the number of lines to read and timing mark format with the sheet being used. Reference: " 4 DIP Switch SW2 Settings" (P.20)
	The paper guide is not properly set.	Set the paper guide properly. If there is a large gap between the paper guide and the sheets, the sheets will not be sent through correctly, and some parts will go unread. Reference: " ■ Setting Sheets" (P.30)
	The sheet is set in the wrong direction (left/right, front/back, etc.).	Set the sheet in the right direction. Reference: " ■ Setting Sheets" (P.30)
	The sheet is deformed.	Use a sheet that is not deformed. Reference: " Inspecting Sheets" (P.24)
	There is a reading error.	Use the included checksheet to perform a reading test.
Double feeding occurs.	The sheet is thicker than the double feed setting value.	Change the paper weight using the Rotary Switch RSW3. Reference: " When double feeding occurs" (P.23)
The computer program does not work properly.	The USB cable or R232C interface cable is disconnected.	Connect it correctly. Reference: " ■ Connect the Communication Cable" (P.17)
	The RS-232C communication settings are not correct.	Set the communication speed and data format correctly. Reference: " 2 Rotary Switch RSW1 Settings" (P.18) and " 3 DIP Switch SW1 Settings" (P.19)

■ Error Indicator

When an error occurs, the ERROR lamp (red) blinks on and the buzzer sounds.

(If the error is hardware-related, the ERROR lamp turns on.)

In SR-1800 mode, the computer can obtain the following status information from the device by sending the command.

In SR-600 mode, the following status information system differs. Refer to the SR-600 Operating Manual.

Error Status	Error	Cause	Action	Status Information
ERROR lamp: (Red) Blinking Buzzer Sound: “ Peep! Peep! Peep!”	Cover open	The top cover is open.	Close the top cover securely.	G1
	Sheet empty	There are no sheets in the hopper.	Insert sheets.	Q1
	Double feed error	2 or more sheets were fed at a time.	Re-set the sheets after loosing them.	Q2
	Sheet skew	The sheet that was fed is skewed.	Check the position of the paper guide, and set the sheet correctly. Reference: “ ■ Setting Sheets” (P.30)	Q3
	Sheet jam	Error due to a paper jam.	Remove the jammed sheet.	H1/H2/H3/H4
	Remaining paper error	There is a sheet left inside the device.	Reference: “ ■ Fixing Paper Jams” (P.38)	T1/T2/T3
	Removal error	After the sheet was fed, it was pulled out.	Re-set the sheet.	R1
	Timing error	The number of timing marks read was 3 or less.	The number of timing marks is 3 or less, or the timing marks cannot be detected. Check the sheet' s timing marks.	R4
	Read setting errors	When reading under the control-type setting, the next timing mark was detected within the range set for reading.	Check that the reading format settings and the sheet content are set correctly.	R5
		When dirt or the sheet folds are detected in the timing mark area.	Clean and fix the sheet folds, then re-set the sheet.	
	Black level error	There is white dirt stuck to the reading unit.	Check the reading unit and wipe off any dirt.	S2
		There is a gap between the paper guide and the sheet.	Check the position of the paper guide, and set the sheet correctly. Reference: “ ■ Setting Sheets” (P.30)	
	Command error, parameter error, protocol error	The sent command, sent parameter, or transmission timing is incorrect.	Check whether or not the sent command, sent parameter, or transmission timing is correct. Check that the USB cable is properly connected.	F5/F6/F7

Error Status	Error	Cause	Action	Status Information
	Back side reader unit not connected	The setting is for using the back side reader unit, but the rear side reader unit is not connected. (Device of single-sided specification)	Turn the back side reader setting to OFF. Reference: "3 DIP Switch SW1 Settings" (P.19)	P1
ERROR lamp (Red) Lights up. Buzzer Sound: " Peep! Peep! Peep!"	Hardware error	Internal error	Turn off the power briefly and then turn the power back on. Check whether or not the same error occurs. If the same error occurs, request for maintenance service.	A1/A2/A4/A5/ A6,B1/B2/B3/ B4/B5/B6/B7

■ Fixing Paper Jams

When a paper jam occurs, fix it according to the following procedure.

- (1) Hold Part A of the top cover and open it, pull upward and remove it.

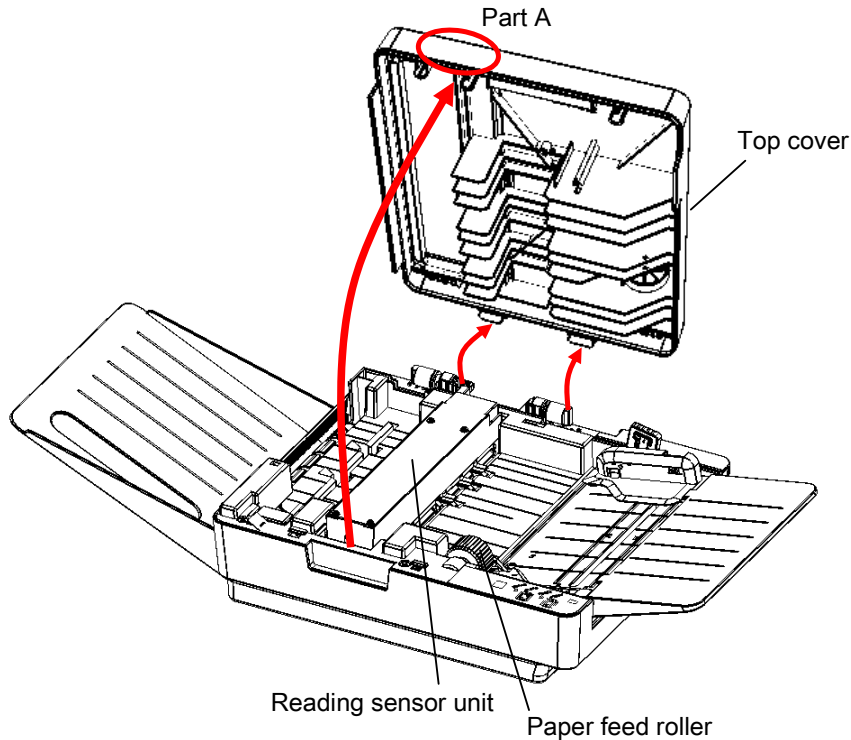

- (2) Remove the sheet that is jammed in the paper feed section.

If necessary, lift up the reading sensor unit to remove the sheet that is jammed.

CAUTION You can lift the reading sensor unit approximately 15mm. Slowly move it vertically up and down, and be careful not to hit the unit against other parts.

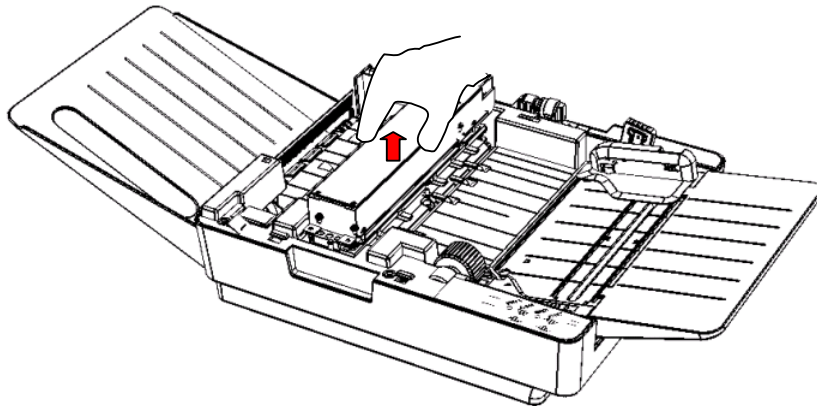

- (3) After the sheet is removed, make sure that there are no remaining bits of torn sheet left in the paper feed section.

CAUTION If bits of torn sheet remain in the paper feed section, it may cause another paper jam. Make sure to remove all of them.

- (4) Reattach the top cover.
Close the top cover securely. Otherwise, it may cause poor paper feeding.
- (5) If the ERROR lamp (red) is on, check (3) and (4) again.
- (6) The following are possible causes of the paper jam.
Check each item and take the necessary action if there is a problem.

Cause	Action
Sheet deformation, ripped sheet, foreign object stuck to sheet	Inspect the sheet. (Reference: " Inspecting Sheets" (P.24)
Dirty paper feed roller, transfer roller	Clean the roller. (Reference: " ■ Cleaning Procedures" (P.41)

Cleaning



Warning

Make sure to turn the power off and remove the power plug from the outlet before cleaning. Failure to do so may result in electric shock.



Caution

External parts are made of plastic. Do not use benzene, paint thinner, or any other volatile substances and chemical solvents. Doing so may result in discoloring or deformation.

■ Regular Maintenance

When the rollers and reading sensors become dirty, various types of malfunction problems may occur. Maintain the device regularly as discussed below. Maintenance frequency will depend on usage (frequency of use, quality of paper used, etc.) When you become aware of dirt or other foreign objects, clean them off.

(1) Cleaning the device and its external parts

Wet a soft cloth with thinned neutral detergent, squeeze it hard and clean the device lightly with it. At this time, prepare a dry cloth as well and wipe the device so as not to leave moisture on it.

(2) Cleaning the rollers

- Clean the rollers according to the frequency of use and the stained conditions since stains on them may be transferred to sheets and may cause a malfunction when sheets are fed (once every a few days).
- Clean the rollers, in particular, after a large number of sheets or sheets fitted with copy carbon are fed.
- Use antiseptic alcohol (ethanol) to clean the rollers.
- Use a soft cloth slightly wetted with antiseptic alcohol (ethanol) to lightly wipe off stains.

(3) Cleaning the Read Sensor

Since the read sensor is covered with optical lens, clean it with a soft cloth or cleaning paper wetted with a small amount of antiseptic alcohol (ethanol) so as not to damage the glass.

CAUTION: Handle the sensor with extreme care since the reading level will be degraded and a reading error may occur if it is flawed.

(4) Maintaining the paper feed path

Wipe off dirt such as bits of torn sheet with a soft cloth or cleaning paper wetted with a small amount of antiseptic alcohol (ethanol).

■ Cleaning Procedures

- (1) Make sure the power is off and the power plug is removed from the outlet.
- (2) Hold Part A of the top cover and open it, pull upward and remove it.

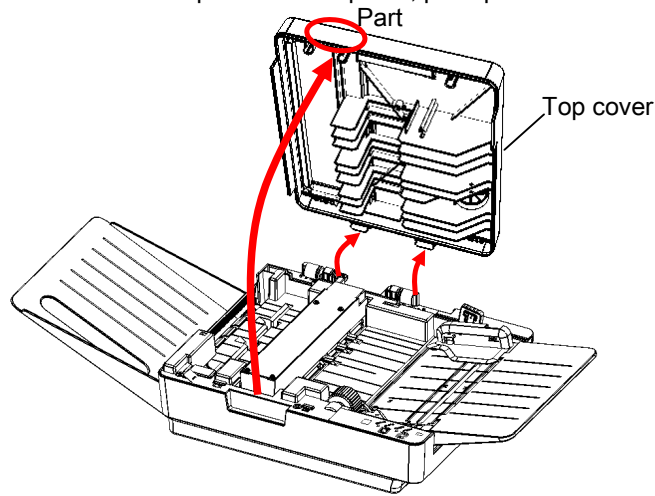

- (3) Clean the necessary parts.

[Roller Parts to Clean]

Roller parts	Paper feed roller (1) Paper feed drive roller (1, top cover) Transfer roller (4) Transfer drive roller (4)
--------------	---

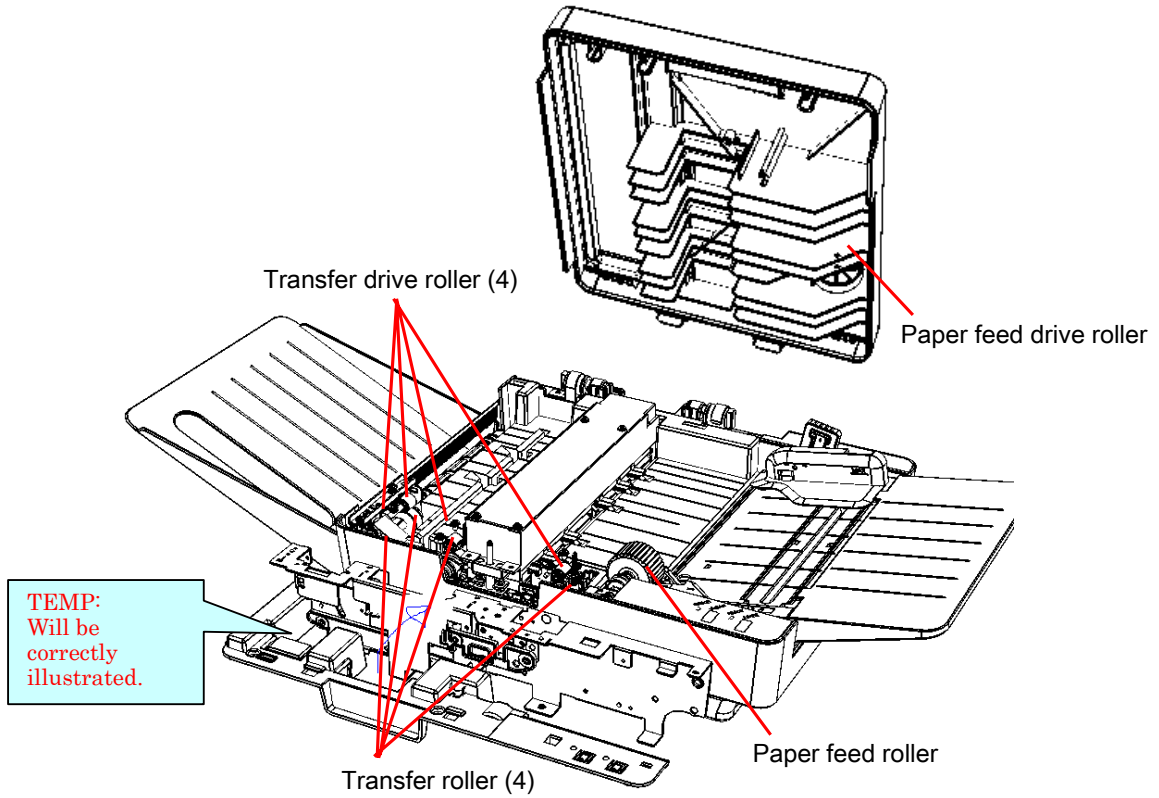

[Part of Reading Sensor Area to Clean]

Reading sensor area	Lift the reading sensor unit and clean the surface of the lens on the bottom of the reading sensor unit. For the device of double-sided reading specification, clean the surface of the lens on the main body side.
---------------------	---

CAUTION You can lift the reading sensor unit approximately 15mm. Slowly move it vertically up and down, and be careful not to hit the unit against other parts.

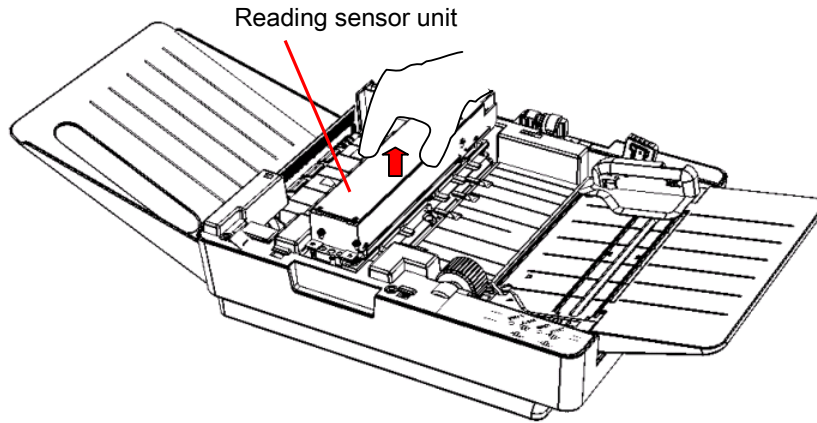

(4) Reattach the top cover.

Service Schedule

For stable operation of this device, regular replacement of components is required.

See the following table, and contact us, or the store where you purchased the device, when requiring component replacement.

Component name	Number	Replacement reference	Remarks
Paper feed roller	1	3 years or 150,000 sheets	
Separator pad (located under the paper feed roller)	1	3 years or 150,000 sheets	Replace at the same time as the paper feed roller

- CAUTION**
- The above number of years and sheets should be considered as a guide.
 - Depending on the device' s usage and environment, the number of years and sheets may differ.
 - For details on when to replace parts, contact the store where you purchased the device.

Product Specifications

Sensor	Reading	Single-sided, double-sided
	Darkness level	16 levels (including no mark)
	Light source color	Near-infrared light (940nm) or visible red light (660nm)
	Pitch (inches)	1/6"
	Marking	Standard: pencil [Visible red light: ball point pen (black, blue)]
	Reading marks	Size: 0.5 x 3mm or larger (recommended mark) Darkness: PCS value of 0.6 or higher
Error detection function	Sheet position detection, double-feeding detection, skew detection	
PC interface	USB (Ver2.0)	
	RS-232C	9,600 to 115,200bps
Operation	Indicator lamps	2
	Operating switches	2
Hopper capacity	50 sheets (paper weight 90kg base)	
Paper used	Paper size	IBM card size, postcard size, A5, B5, A4, (Width 8.5 inches, 9 inches) Height: 110 to 355.6mm (4.3 to 14 inches) Width: 63.5 to 228.6mm (2.5 to 9 inches)
	Paper weight	72 to 135kg (84g/m ² to 157g/m ²)
	Paper quality	OCR paper, high quality paper, recycled OCR paper (recycled OCR paper composition 70% or less)
	Sheet feeding	Feeding speed
Sheet discharge	Stacker capacity	100 sheets (when 90kg base paper weight is used)
Power source	AC100 to 240V, 50Hz/60Hz	
Environmental operating conditions	Temperature	5 to 35° C (41° F to 95° F)
	Humidity	30 to 80%RH (no condensation)
External dimensions	390(W) x 127.5(H) x 326(D) mm (15.4(W) x 5(H) x 12.8(D) inches) (not including paper feed tray and stacker)	
	731(W) x 127.5(H) x 326(D) mm (28.8(W) x 5(H) x 12.8(D) inches)	
Weight	4.9kg (10.8 lbs), for single-sided specification (not including AC adapter)	
Noise	60dB(A) (when operating)	

External Dimensions Diagram

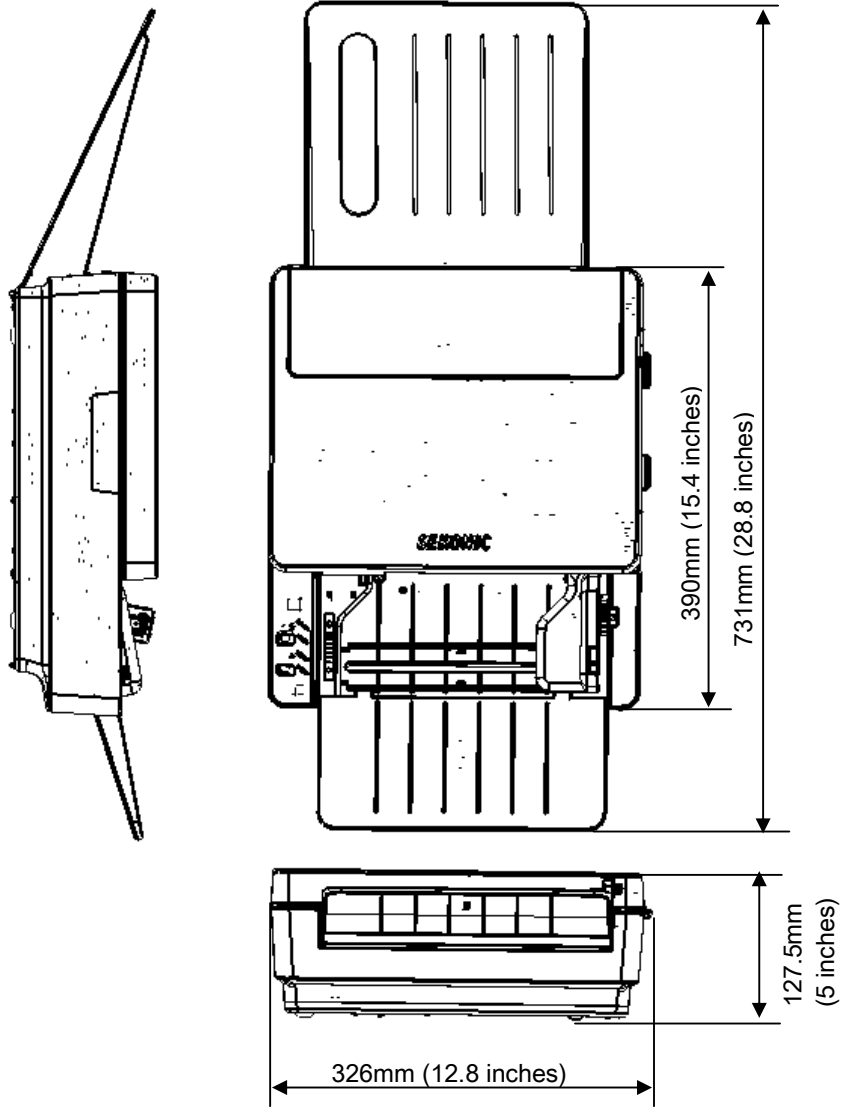

OMR glossary

Column and Row

Mark frames are in columns, timing marks are in rows.

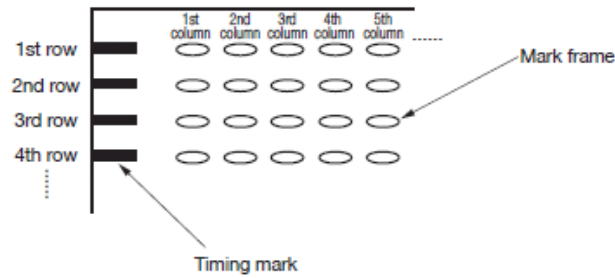

Jam

A paper jam error caused by media when paper is being fed.

There are two kinds of jams: static jams detected when the device is at rest, and operational jams detected while the device is running.

Operational jams include double-feeding jams and no-feeding jams.

Skew

Refers to paper that is slanted against the paper feeding standard.

This function detects whether or not paper is fed straight.

Perforated paper, paper unevenly cut, and curled or bent paper is likely cause skew errors.

Stacker

This refers to the place that sheets that have been read are temporarily stacked.

Stacker volume refers to the number of sheets that can be accommodated.

Example: stacker volume 200 sheets.

Timing control type

If paper has pre-printed timing marks, the scanning area (reading area) of targeted mark frames will be determined by such timing marks.

Timing control type is a method to determine the reading zone based on the timing mark width. ~~Other methods include direct under type, mark to mark type, and FACOM type.~~

Example: Timing control type to scan three times the timing mark width.
Set multiple numbers using the software controlling OMR.

• Top-end timing control type:

Reads n times the width of a timing mark from the beginning of the timing mark.

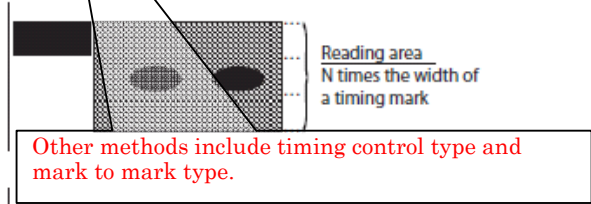

• Bottom-end timing control type:

Reads n times the width of a timing mark from the end of the timing mark.

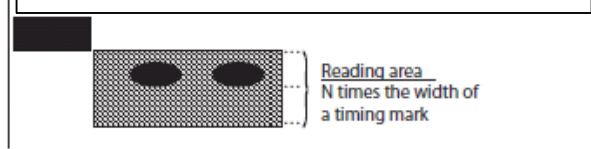

Sensor (for reading) Reading sensor/position sensor

Sensors are photoelectrical elements that transform reflected light. Sometimes sensing refers to both light emission and light reception.

LED wavelength influences dropout color. We use mainly two wavelengths, and the relationships between wavelength, dropout colors, and readable colors are shown in the table below.

Wavelength	Color	Dropout color	Readable color
940nm	Infra red	Colors other than readable colors	Black and blue pigments
660nm	Visible light (red)	Red, orange, pink	Black, blue

Sorter

On a device with two or more stackers, this is a unit that can sort paper based on information such as kind of paper and written marks.

Direct under type

If paper has pre-printed timing marks, the scanning area (reading area) of targeted mark frames will be determined by such timing marks.

Direct under type refers to a method of reading a zone that is the same as the timing mark width.

~~Other methods include timing control type, mark to mark type, and FACOM type.~~

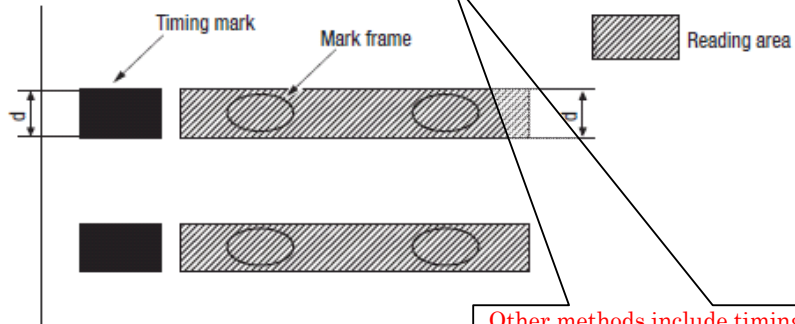

Other methods include timing control type and mark to mark type.

Transmission Interface

The hardware connecting a computer and the OMR, in other words the mediating connection. The SR-3500,SR-6500 uses USB or RS-232C interfaces.

Dropout color

Refers to colors pre-printed or written on documents that people can see but that don't appear when read with an image scanner or other devices.

There are "warm colors" and "cold colors" by appearance. Warm colors called orange end, red end, etc. are used as OCR dropout colors, and you need to switch filters in this device for bluish dropout color sheets such as the standard forms used by the Japan Chain Stores Association. Bluish colored lines drop out when they are scanned with copy machines and other devices even if they don't use dropout color ink. OCR paper for fax machines uses "cold color (blue-green)" dropout colors, but there are only a few colors that can be used with most fax machines, because they are different from OCR units.

- (1) Dropout color print darkness is controlled by the PCS value. There are two ways to measure PCS, black backing and white backing, and you should pay attention because they differ depending on the model.
- (2) OCR sheets are generally used for printing character boxes using dropout color inks and printing letters in clear areas.
- (3) Recently, some models have become available that are capable of reading black character boxes, but dropout color printing sheets are often superior in both recognition performance and processing speed.
- (4) Dropout colors are chosen by spectral characteristics and PCS values that are determined by scanner sensor, light source, and filter.

- (5) Colors that can be used as dropout colors differ depending on the model, but with some models, even regular ballpoint pen ink drops out and cannot be used. In such cases, you need special OCR ballpoint pens that are rarely available today. See table below for relationships between wavelengths and colors.

Peak sensitivity wavelength	Color	Remarks
740(nm)	Sepia Magenta Purple Brown	Abundant dropout colors Some ballpoint pens cannot be used.
	Bluish tones Greenish tones	
660	Rose Pink	For red end colors only, rose aniline, purplish red, deep red Regular ballpoint pens can be used.
	Red Orange	
570	Yellow	As in fax scanners, it's difficult to see with human eyes → should be avoided. Regular ballpoint pens can be used.
530	Blue	Regular ballpoint pens can be used for blue-end colors only. Green
	Green	

- a) It is important to control the PCS value to print dropout colors. (You need to choose a printer equipped with devices that can measure PCS values.)
- b) If you want to use an abundance of colors, we recommend printing in ink other than dropout colors as a "black frame sheet."

No feed

Refers to paper doesn't get fed during paper feeding operations. If such an error occurs, the device assesses it as a paper feeding error, and notifies user of the error.

PCS (printed contrast signal)

Refers to the reflectance ratio (contrast) of printed marks, symbols, and letters as opposed to reflectance of non-printed areas. The calculation formula is as follows.

$$PCS = \frac{\text{White reflectance} - \text{black reflectance}}{\text{White reflectance}}$$

When reflectance of areas with no printing is 70%, and reflectance of printed marks, symbols, and letters is 10%, the PCS will be 0.857.

Writing Implements

Readable marks and unreadable marks depend on the writing instruments used. This can also differ according to the light source that the reading sensor uses.

Relationships between sensors used for OMR (light source) and writing implements

Light source wavelength	Color tone	Readable mark colors and writing implement	Unreadable mark colors and writing implement
940nm (standard)	Infra red	Color: black (pigment) Writing implement: pencil	Color: other than black Writing implement: other than pencil
660nm (*Option)	Visible light (red)	Color: black, brown, blue, green, purple Writing implement: pencil, fountain pen, water/oil base ballpoint pen, water/oil base marker	Color: red, orange, yellow Writing implement: items in above colors

"FACOM" type

If paper has pre-printed timing marks, the scanning area (reading area) of targeted mark frames will be determined by such timing marks.

FACOM type refers to a method of determining the reading zone based on a pair of start timing and stop timing marks. Other methods include timing control type, direct under type, and mark to mark type.

The diagram illustrates the FACOM scanning process. A vertical line on the left indicates the scanning path. Two horizontal bars labeled 'Start timing' and 'Stop timing' are positioned on this line. To the right of the start timing bar are several horizontal bars labeled 'Timing mark'. Further to the right is a larger rectangular area labeled 'Mark frame' which contains two circles. To the far right is a small rectangular area labeled 'Reading zone'.

Hopper

A place to put sheets to be processed for marking and compilation.

Mark to mark type

If paper has pre-printed timing marks, the scanning area (reading area) of targeted mark frames will be determined by such timing marks. Mark to mark type is a method to read zones between two timing marks. Therefore, the number of timing marks in mark to mark type forms is always an even number. ~~Other methods include timing control type, direct under type, and FACOM type.~~

Other methods include timing control type and direct under type.

- Mark to mark type
(without top-end margin reading):
The reading zone is the area between timing marks.

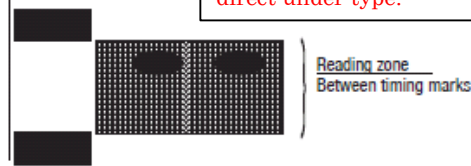

- Mark to mark type
(with top-end margin reading):
The reading zones are the front margin of the form as the first row, and between timing marks as the second and subsequent rows.

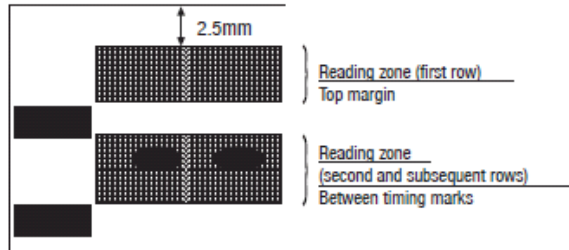

Double-feeding

Refers to two or more sheets being fed at the same time during paper feeding operation. If such an error occurs, the device assesses it as a paper feeding error, and notifies users of the error.

Form

- (1) OCR paper (optical character recognition paper)
Paper for data processing to optically read letters and symbols. It should not be dusty, and it should be smooth, stiff, abrasion resistant, and antistatic.
JIS X 9004 (printing specifications for optical character recognition)
- (2) Quality paper
Paper made from pure chemical pulp. Used for printing and writing.
JIS P 3101 (printing paper) JIS P 3201 (writing paper)
- (3) Paper weight
Paper is categorized by weight.

Appendix

■ Sheet creation reference

Height 110-335.6mm (4.3-14 inches), Width 63.5-228.6mm (2.5-9 inches)

You can use paper that you make yourself with this device in addition to the optional paper that we offer. If you make your own paper, follow the specifications below.

- (1) Sheet size
~~Height 110-335.6mm Width 63.5-228.6mm~~
 Do not cut or round the corners on the reference side (timing mark side).
 (See P.iv)

- (2) Weight and thickness

g/m2 (grams per sheet)	84 - 157
mm (thickness)	0.1 - 0.19

- (3) Paper quality
 OCR paper, quality paper, or recycled OCR paper.

- (4) Printing ink (printing surrounding mark fields)
 When the wavelength of the OMR reading sensor light source is 940nm, use spectrum band B900 to measure the PCS and use ink at PCS 0.15 or less. Print timing marks in ink at PCS 0.85 or higher.
 When the wavelength of the OMR reading sensor light source is 660nm, use spectrum band B680 to measure the PCS and use ink at PCS 0.15 or lower. Print timing marks in ink at PCS 0.85 or higher.

- (5) Printing position accuracy
 - Parallelism Adjust printing parallelism for timing marks and data marks 0.2mm or less based on the cutting edge of the timing mark side.
 - Perpendicularity Adjust printing perpendicularity for timing marks and data marks 0.2mm or less based on the cutting edge of the timing mark side.
 - Other Adjust to ±0.2mm or less of specified measurements unless otherwise specified.

- (6) Prohibited printing zones
 Do not print between timing marks, or between the top-end (bottom-end) timing mark and the top edge (bottom edge) of the mark sheet.
 Top-end margin*: 9mm or more from the top edge to the first timing mark.
 Bottom-end margin: 9mm or more from the last timing mark to the bottom edge.
 Side margin: 4mm or more on the opposite side of the sheet's standard edge.
 *For IBM card size, top end margin is 5mm or more, bottom- end margin is 6mm or more

- (7) Direction of paper grain
 Feed paper in the direction of its grain to eliminate curling.



-i-

- (8) Clear zones
Do not print in colors other than dropout colors 0.8mm around reading zones and 0.8mm from timing mark longitudinal ends.

Reading zone:

The vertical direction of the data mark standard position is the height set by command, and the horizontal width refers to the area of the data mark frame width.

Dropout colors:

Dropout colors refers to colors that are already printed or written on a document that can be seen by human eyes but cannot be recognized by a reading sensor.

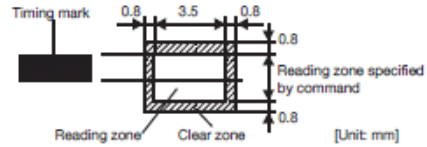

- (9) Black ink printing
Descriptions, etc. can be printed in areas except print prohibition zones and clear zones. However, never print anything at PCS 0.15 or more other than timing marks in timing mark columns from the top edge of sheet to the bottom edge on either side of the paper.

- (10) Printing on back surface
You can print on the back surface except in print prohibition zones. However, do not print at PCS exceeding 0.15 in clear zones on the front surface in case of bleeding through from the back.

- (11) ID mark
Set an ID mark for identification as necessary.
Size: 1.0mm or longer x 3mm or longer.
Reading darkness: PCS 0.8 or higher
Angle: ±5 degree or less (against the line perpendicular to the standard side)

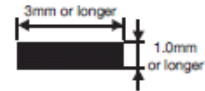

- (12) ~~Mark frame~~
Rectangles, ovals, and circle shapes have been conventionally used for mark frames.

Mark frame (Reading mark size)

Frame size should be smaller than the reading zone in various reading methods (~~direct under type, timing control type, mark to mark type, and FACOM type~~).

Recommended sizes are as follows.

Rectangles: Vertical 0.8-1.5mm Horizontal 3-3.5mm

Ovals: Vertical 1.5-2.5mm Horizontal 3-4.3mm

Circles: O 3.0-3.5mm

*Maximum horizontal length differs depending on sensor pitch.

Adjust horizontal length = (sensor pitch - 0.7mm) or less.

*Printing color: print at PCS 0.15 or less in dropout color.

(direct under type, timing control type and mark to mark type).

(13) Paper dimensions
[Direct under type sheet]

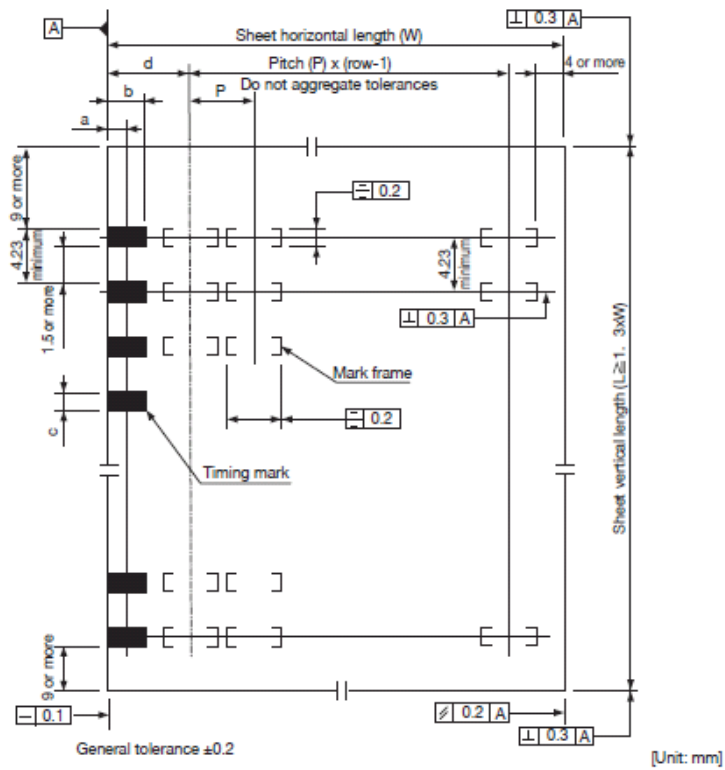

Size	W x L (mm)	Maximum number of columns				Maximum number of rows
		1/6	0.2	0.25	0.3	
IBM*	82.55 x 187.3	16	13	12	9	40
Postcard	100 x 148	20	17	14	11	31
A5	148 x 210	31	25	22	17	46
B5	182 x 257	39	31	27	21	57
A4	210 x 297	46	38	32	25	66
8.5"	216 x 279	47	40	33	26	62
9"	228.6 x 355.6	48	40	33	27	80

- Note 1) Timing mark width: maximum width of c is 12mm.
- Note 2) Maximum number of rows indicates the number of timing marks.
- Note 3) Printing specifications for IBM card size are described on the next page.

[Direct under type card (0.25" IBM card size)]

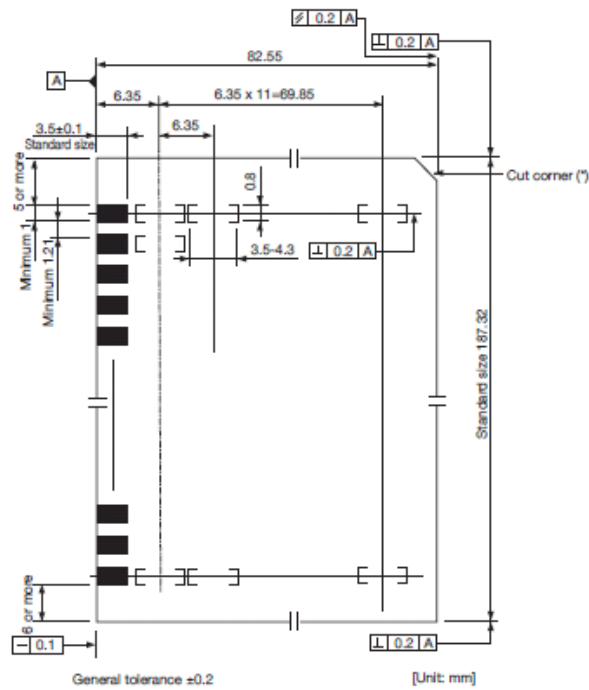

* Cut corners and round corners

They help you to easily check if paper is placed in the right direction, and help you to manage paper and keep it orderly.

Cut paper corners straight or rounded according to the specifications shown below.

Straight cut corners: standard 6mm or less.
Chamfer angle 45°

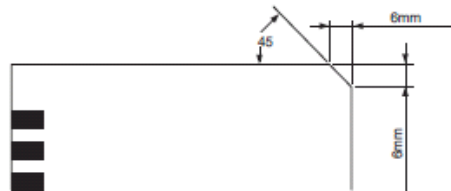

Round corners: R 6mm

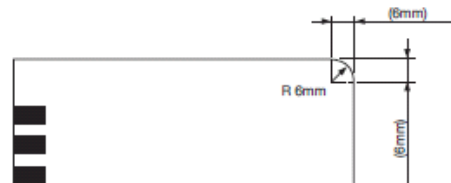

[Timing control type sheet]

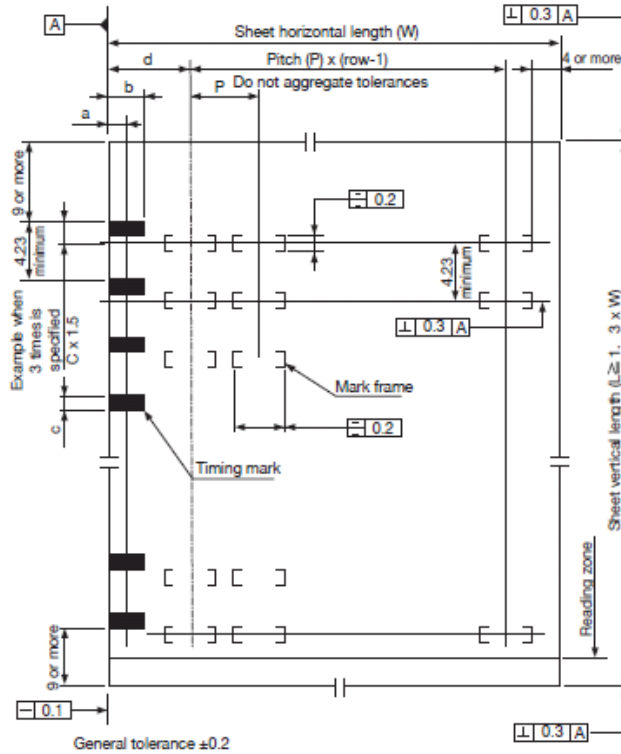

	Size	W x L (mm)	Maximum number of columns			Maximum number of rows	
			1/6	0.2	0.25		0.3
	IBM*	82.55 x 187.3	16	13	12	9	40
	Postcard	100 x 148	20	17	14	11	31
	A5	148 x 210	31	26	22	17	46
	B5	182 x 257	39	33	27	22	57
	A4	210 x 297	46	39	32	25	66
	8.5"	216 x 279	47	40	33	26	62
	9"	228.6 x 355.6	48	40	33	27	80

	1/6	0.2	0.25	0.3
a	6.99	5.71	1.78	1.5
b	3.81	3.11	3.56	5.0
c	0.89	0.89	0.89	0.89
d	11.43	11.75	6.35	4.5

- Note 1) Timing mark width: maximum width of c is 12mm.
- Note 2) Maximum number of rows indicates the number of timing marks.
- Note 3) Set magnification values in order for the gap to be possible 1.4 mm or more from the top-end of next timing mark.

[Mark to mark type sheet]

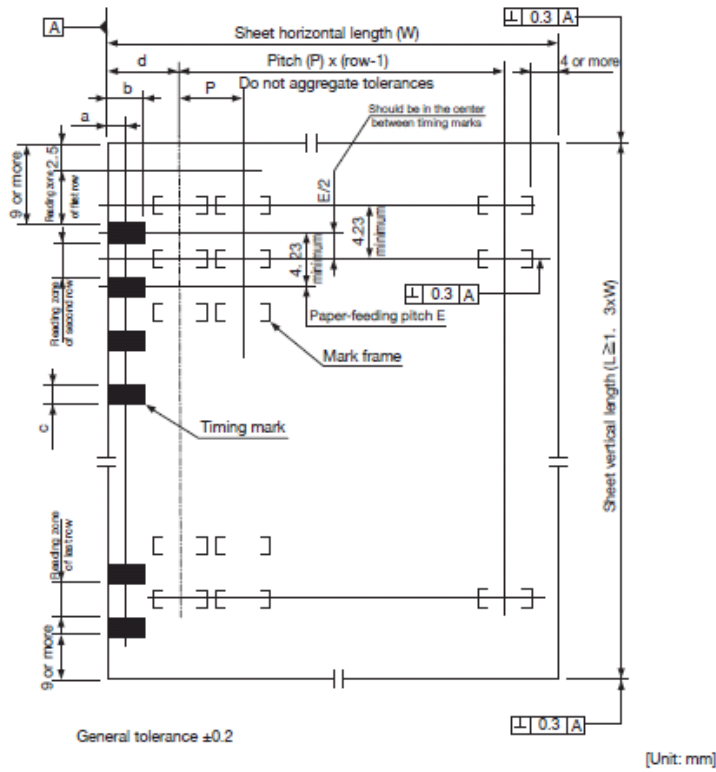

					Size	W x L (mm)	Maximum number of columns				Maximum number of rows
	1/6	0.2	0.25	0.3			1/6	0.2	0.25	0.3	
					IBM*	82.55 x 187.3	16	13	12	9	40
					Postcard	100 x 148	20	17	14	11	31
					A5	148 x 210	31	27	22	17	46
					B5	182 x 257	39	33	27	21	57
					A4	210 x 297	46	39	32	25	66
					8.5*	216 x 279	47	40	33	26	62
					9*	228.6 x 355.6	48	40	33	27	80
a	6.99	1.91	1.78	2.5							
b	3.81	3.81	3.56	1.00							
c	1.0	1.0	1.0	1.0							
d	11.43	11.7	6.35	14.5							

- Note 1) Timing mark width: maximum width of c is 12mm.
- Note 2) Maximum number of rows indicates the number of timing marks.
- Note 3) Printing specifications for IBM card size are described on the next page.

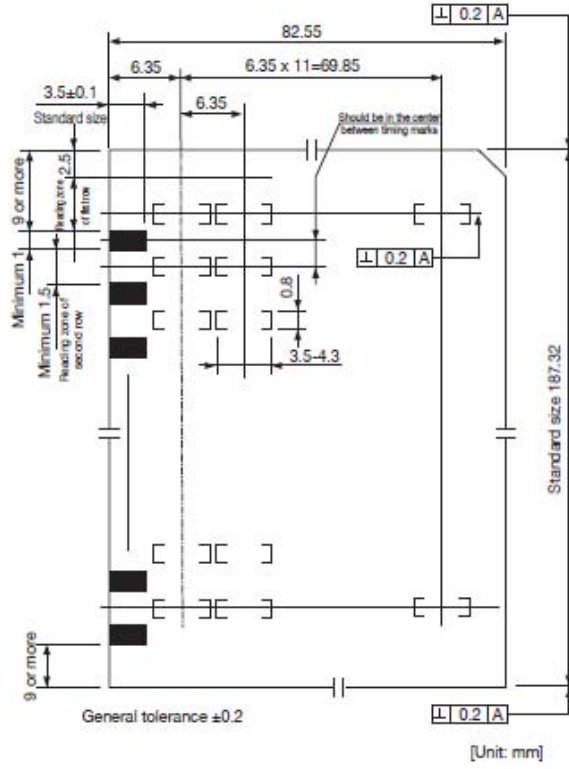

SEKONIC CORPORATION

7-24-14, Oizumi Gakuen-cho, Nerima-ku, Tokyo 178-8686, Japan
Telephone: +81-3-3978-2375 Facsimile: +81-3-3978-5229